

United States
Department of
Agriculture

Forest Service

National
Technology and
Development
Program

7700—Transportation Mgmt
November 2005



NATIONAL INVENTORY AND ASSESSMENT PROCEDURE—For Identifying Barriers to Aquatic Organism Passage at Road-Stream Crossings



NATIONAL INVENTORY AND ASSESSMENT PROCEDURE—For Identifying Barriers to Aquatic Organism Passage at Road-Stream Crossings

**U.S. Department of Agriculture Forest Service
National Technology and Development Program
444 E. Bonita Avenue
San Dimas, CA 91773**

By: Kim Clarkin—Project Manager

National Technology and Development Center
San Dimas, CA.

Anne Connor

USDA FS Clearwater National Forest, Orofino, ID

Michael J. Furniss

USDA FS Pacific Northwest Research Station, Corvallis OR

Bob Gubernick

USDA FS Tongass National Forest, Petersburg, AK

Michael Love

Michael Love and Associates, Eureka, CA

Kathleen Moynan

US Fish and Wildlife Service, Region 1, Portland, OR

Sandra WilsonMusser

USDA FS Region 6, Portland, OR

Information contained in this document has been developed for the guidance of employees of the U.S. Department of Agriculture (USDA) Forest Service, its contractors, and cooperating Federal and State agencies. The USDA Forest Service assumes no responsibility for the interpretation or use of this information by other than its own employees. The use of trade, firm, or corporation names is for the information and convenience of the reader. Such use does not constitute an official evaluation, conclusion, recommendation, endorsement, or approval of any product or service to the exclusion of others that may be suitable.

The U.S. Department of Agriculture (USDA) prohibits discrimination in all its programs and activities on the basis of race, color, national origin, age, disability, and where applicable, sex, marital status, familial status, parental status, religion, sexual orientation, genetic information, political beliefs, reprisal, or because all or part of an individual's income is derived from any public assistance program. (Not all prohibited bases apply to all programs.) Persons with disabilities who require alternative means for communication of program information (Braille, large print, audiotape, etc.) should contact USDA's TARGET Center at (202) 720-2600 (voice and TDD).

To file a complaint of discrimination, write to USDA, Director, Office of Civil Rights, Room 326-W, Whitten Building, 1400 Independence Avenue, S.W., Washington, D.C. 20250-9410, or call (800) 795-3272 (voice) or (202) 720-6382 (TDD). USDA is an equal opportunity provider and employer.

TABLE OF CONTENTS

I.	Introduction	2
II.	Geographic Scope and Specific Objectives of the Inventory	5
	A. Deciding where to conduct the inventory	5
	B. Deciding on inventory objectives	6
III.	Field Work Preparation	10
	A. Locating the crossings to be inventoried	10
	B. Keeping track of the crossings	11
IV.	The Inventory	12
	A. Reviewing office information	12
	B. Collecting the necessary equipment	13
	C. Training the field crew	12
	D. Conducting field work	12
	E. Ensuring safe procedures	13
V.	Passage Assessment	14
	A. Developing the regional passage screen	14
	1. Introduction	14
	2. Screen criteria	16
	a. Crossings that resemble the natural channel	16
	b. Fishways: baffles and weirs	17
	c. Regionally defined analysis species criteria	17
	B. Conducting hydraulic analysis	22
	1. Flow selection	22
	2. Swim performance	22
	3. Fish Crossing limitations	22
	C. Summarizing crossing category for the analysis species	22
VI.	Prioritization of Road Crossing Treatments	24
	A. Establishing the larger watershed context	24
	B. Protecting areas from invasive species	24
	C. Developing a scheme for setting priorities	25
	D. Finding sources of habitat quality and quantity information	26
VII.	References	28

Figures

V-1.	Passage Assessment Process	15
V-2.	First-phase Evaluation Filter developed for California	20
V-3.	Assessment Matrix Example from USFS Region 10	21

Appendices

A.	Example Prioritization Scheme: Rating Criteria from California	30
B.	Fill-in-the-Blank Regional Screen, California model	33
C.	Passage Flow Requirements from some States	34
D.	Example Job Hazard Analysis—Umatilla National Forest	35
E.	Field Form and Line by Line Instructions	37

ACKNOWLEDGMENTS

This procedure is based on several other fish passage evaluation procedures including: Taylor and Love (2001), USDA Forest Service Region 10 (2001) and USDA Region 6. We have also incorporated ideas from the Washington Department of Fish and Wildlife's manuals on fish passage design and barrier assessment (Washington Department of Fish and Wildlife 2000). Those sources are not responsible for any errors or misinterpretations herein.

I. INTRODUCTION

This inventory procedure is designed to be a nationally applicable, consistent method of identifying crossings that impede passage of aquatic organisms in or along streams. It is a how-to manual for approaching answers to two questions raised in United States Department of Agriculture (USDA) Forest Service *Roads Analysis*, [1999, p. 67, AQ(10)]: “How and where does the road system restrict the migration and movement of aquatic organisms; what aquatic species are affected and to what extent?”

Full answers to these questions are essential to managing roads and planning for restoration. A transportation plan must consider and be designed to mitigate the road network’s effects on aquatic ecosystems and their continuity. And planning for restoring watersheds and setting priorities cannot logically proceed without considering how fragmented the aquatic habitat is and how important it is relative to the suite of restoration needs of the whole watershed.

The inventory protocol is data-intensive because it is designed to produce enough information from a single site visit to answer the following questions:

- Are crossing conditions adequate for specific species and life stages?
- What is the approximate cost of replacement?

The inventory does not yield all the information needed to determine which crossings should be prioritized for replacement. Generally, data on species presence and habitat quality are needed in addition to the physical data collected here. The inventory also does not yield enough information for design of a replacement structure. Depending on the site, the design process may require much more information, such as a full site survey and a geomorphic assessment.

The site assessment procedure begins with an evaluation of the degree to which a crossing resembles the adjacent stream form and function. Crossings that maintain stream functions are essentially invisible to the stream, and so are more likely to pass the resident species inhabiting the stream. The research that could confirm the hypothesis that crossings resembling the adjacent stream pass all resident aquatic and semi-aquatic species has not been done. Given that direct evidence is unavailable, and crossing assessment and restoration will proceed, it is reasonable to assume that species movement needs will be accommodated by crossings that do not disrupt the stream channel’s form and function.

If a crossing does not resemble the adjacent stream channel, then regionally defined measurable criteria (hereafter referred to as regional screens) are used for preliminary assessment of passage for a particular species, life stage, or species group. For fish, a hydraulic model is available when the regional screen fails to determine whether a crossing provides adequate conditions for the analysis species. The model we use is FishXing, which compares crossing hydraulics to swimming and leaping capabilities of individual fish species and life stages. Regardless of whether the analysis

is completed using the screen or the model, the process results in a defining a crossing category for each of the analysis species (see section V.C. for category definitions). Consistent identification of crossing category for individual species will permit unambiguous data aggregation across regions and the nation.

Streams and roads that cross affect each other in important, potentially destructive ways. Until recently, these two networks have been managed relatively independently by different groups of resource specialists. The sometimes destructive results have led to the realization that managing streams and road must consider the needs and character of both, something best accomplished by interdisciplinary teamwork. As noted in Roads Analysis (USDA-FS 1999 p. 67), a successful approach to these problems must draw from fisheries and wildlife biology, hydraulics, engineering, geomorphology and hydrology. Ideally an interdisciplinary team of trained specialists will be used to collect the data and interpret it in ways that address management questions.

In most cases, fisheries issues usually prompt culvert inventories. But many other aquatic and semi-aquatic species also use stream crossings and are affected by even low volume roads: amphibians, reptiles, invertebrates and small mammals. Information on passage needs and capabilities for these groups is scarce, but some information can be found at www.wildlifecrossings.info.

Inventory and Assessment Procedure Overview

The following summarizes the barrier inventory-assessment process and highlights important recommendations.

Establish the watershed context

- Build and overlay maps of streams, roads, land ownership, analysis species distributions, aquatic habitat types, and habitat quality.
- Population and habitat information from field surveys is highly preferred because the assumptions used to estimate these variables from maps are often inaccurate.

Collaboratively establish criteria for regional screens

- Develop analysis species lists and criteria with the assistance of aquatic experts and in collaboration with a group of stakeholders including land management and regulatory agencies, as well as other interested parties (such as, tribes, Departments of Transportation).
- Document assumptions and rationale.

Conduct the field inventory

- Include crossings on all land ownerships if possible; otherwise, conduct the analysis recognizing the gaps in knowledge.
- Collect the entire suite of variables on all crossings to permit later reevaluation if needed
- Use interdisciplinary teams to collect and interpret the data

Determine barrier category: natural channel resemblance or species-specific crossing category

- Use regional screens for rapid field assessment of natural channel simulation and barrier category.
- Use hydraulic analysis where screens fail to determine barrier category.
- Understand the limitations of the analytic procedure, such as:
 - For many species, movement capabilities and needs are unknown.
 - Estimates of culvert velocity are based on imprecise roughness values and may not accurately reflect the flow conditions faced by fish.

Map barrier locations and overlay on habitat-quality maps to set priorities for restoring connectivity

- Set priorities for replacements aimed at maximum biological benefit in conjunction with logistical considerations.
- Collaborate with partners and other stakeholders to set priorities.

II. GEOGRAPHIC SCOPE AND SPECIFIC OBJECTIVES OF THE INVENTORY

A. Deciding where to conduct the inventory

Unless resources are available to cover an entire area of interest, (such as the whole forest), or funding is designated for a certain area, priorities must be set among areas to inventory. Ideally, watershed analyses are complete, and the road analyses are underway or complete. If so, answers to the following questions will already be available. If not, an interdisciplinary team should gather the background information needed to answer the questions. It is essential to think in terms of watersheds, rather than just about road systems, because the main issue is one of upstream-downstream continuity for the local biota.

1. Which watershed(s) should be surveyed first?

One of the functions of the barrier inventory is to identify the most biologically beneficial improvements. To meet this objective, we need a basic understanding of the needs of the biota and the condition of the aquatic ecosystem in the general area. We need to answer questions like: What spatial and temporal habitat needs are related to the life-history requirements of the species? What are the general conditions of the watershed's habitats as related to species requirements? Do road and topographic conditions in the watershed pose a risk to high quality habitats? For example, are there miles of infrequently maintained unclassified or legacy roads on steep lands, where crossing failures during floods could damage downstream habitat?

This information can then be used to identify watersheds that are high priority for barrier inventories. Some examples of watershed characteristics that may lead to high priority for inventory are:

- Watersheds that are important refugia for certain species or aquatic communities
- Watersheds that create a connected block of habitats needed to support the life history requirements of species in the general area
- Watersheds with critical or essential habitat for one or more threatened or endangered aquatic species or have species with economic or cultural value.
- Watersheds with high native biological diversity
- Watersheds with known barriers excluding species from critical habitats
- Watersheds with habitat quality problems that could result in greater species effects if barriers exist (such as, high temperature, low dissolved oxygen, or low food productivity)
- Watersheds where barriers may be desired to exclude invasive exotic species.

Other logistical or practical considerations may also focus an effort on a particular watershed. For example, existing major road maintenance or reconstruction needs, and existing or potential partnerships with other landowners could also be criteria for selecting a watershed for inventory.

2. Will crossings on all ownerships be inventoried?
 How will jurisdictional boundaries be handled?
 Are there any potential partners?
- Building a general picture of the watershed before planning the inventory is essential for many reasons. An extensive coordination effort may be needed to inventory crossings in an area with multiple jurisdictions. Generally, one agency or entity spearheads the effort, with various amounts of commitment from other landowners. Additional opportunities may be found for leveraging funding from various sources when several landowners are cooperating to assess barriers.
- If cooperation cannot be secured, landowners may agree to inventory only crossings on their own land or under their own jurisdiction. Information on habitat quality and quantity—and on upstream and downstream barriers—would still be needed for areas in the watershed under other ownership or jurisdiction. Without that information, the importance of removing barriers on any one jurisdiction may be hard or impossible to determine.

B. Deciding on inventory objectives

This inventory and assessment procedure supports one core objective and three additional objectives.

The **core objective** is to determine the crossing category for each analysis species.

The protocol includes two methods for achieving this objective. One method uses species and lifestage specific criteria in a flow chart (see section V.A. Regional Passage Screen); the other uses the hydraulic model FishXing (See section V.B. Hydraulic Analysis). Headings in bold on the inventory data sheets indicate the data are related to the core objective.

The **additional objectives** are to: 1) prioritize passage improvement projects, 2) develop replacement project budget cost estimates, and 3) field validate flows used to evaluate passage in FishXing. Headings in regular font indicate the data are related to the additional objectives, and optional.

There may also be other objectives for conducting the inventory. For example, a possible complementary objective is to assess crossings for risk of failure during floods, and their probable consequences on downstream areas. See #5 below for more information about this objective. The full set of objectives should be identified prior to going into the field in order to ensure the data needed to achieve those objectives are collected.

The field protocol described in this document will produce the information needed to accomplish the core objective and the additional three objectives listed above. To prioritize passage improvement projects, the inventory data will need to be combined with an understanding of up-and downstream habitat quantity and quality.

1. Is the objective simply to map sites that are barriers? Will you require additional information to help prioritize passage restoration projects?

The objectives for the inventory may be limited to defining the extent of the barrier problems in a watershed. More often, they will be broader, and include gathering information needed to prioritize crossings for treatment. While there are likely to be a wide variety of prioritization criteria developed by different administrative units, most will probably include information about the quantity and quality of the habitat that would be opened up when the site is improved. Both upstream and downstream movements can be impeded by crossing structures depending on the species (Warren and Pardew 1998), so it is important to understand the movement patterns of the analysis species (and life stages) to determine which movements need to be considered for prioritization. See section VI for more detail about how habitat information is used in the prioritization process.

2. For what species, life stages, or life stage groups will passage be evaluated?

Unless an ecological reason exists for excluding species, the ideal crossing is one that passes **all** aquatic and terrestrial species that require stream or streamside zones to move⁸. Although definitive data are lacking, we believe it is reasonable to assume that the aquatic and semi-aquatic organisms that normally move through an area will be able to pass through crossings that closely resemble the adjacent natural channel reaches. Such crossings generally do not require species-specific analyses. [See section V.A.2.a for criteria that can be used to determine if the crossing resembles the adjacent natural channel.] Most crossings, however, do not mimic the adjacent stream, and they require other methods of passage evaluation, including comparing conditions at the crossing to regionally developed species-specific criteria. For fish species with known swim performance, hydraulic assessments can be conducted.

Information about how to assess road crossings for passage by amphibians, reptiles, invertebrates, and small mammals is limited. These non-fish species groups may or may not be a focus of the inventory; where they are, passage determinations should be based on inferences from information about the basic capabilities and needs of the species, and professional judgments of experienced technical experts.

The Analysis Species—Passage determinations are based on criteria developed from swimming and leaping capabilities of individual species, life stages (size), or species groups with similar morphology or known swimming ability and behavior (hereafter collectively referred to as the analysis species). The procedure described in this document provides enough data to assess passage for many fish species in many situations. Your list of analysis species may be broader and include species other than fish, however. Because additional data might need to be collected for these non-fish species, we recommend identifying specific analysis species in the planning stages. These are the species, life stages, or species groups for which regional screens will need to be developed.

⁸ Road construction and maintenance in streams is often permitted under the Corps of Engineers nationwide permit that includes the following General Condition [65 FR March 9, 2000, page, 112893; Section C.4 Aquatic Life Movements] “No activity may substantially disrupt the movement of those species of aquatic life indigenous to the waterbody including those species which normally migrate through the area. Culverts placed in streams must be installed to maintain low flow conditions”.

The following steps are recommended in choosing analysis species:

- Make a list of the species currently or historically present in the inventory area that require passage.
- Contact state and federal agencies to determine if any species have established passage requirements or recommendations.
- Review available information about the movement requirements of the species on the initial list.
- Determine which species, life stages, or species groups have the greatest movement limitations or are the species of concern in your inventory area. These species should serve as the analysis species for passage evaluations.
- Document the rationale for your choice(s) in the analysis species, lifestage, or species group comment section on the field form, page 7 (such as, the weakest swimming species, lifestage, or species group, an ESA-listed species, a culturally or economically important species, an indicator species).

3. Will all crossing types be evaluated?

Although most crossings in the United States are culverts, crossings also include fords, vented fords, and various types of bridges. Bridges are generally assumed to be passable by all aquatic and most if not all riparian-dependent species; but there may be instances where there are passage issues. Some examples include: a short bridge that constricts channel width and increases water velocity, or where rip-rap placed for scour protection results in rock cascades that inhibit or prevent passage. Some structures that look like bridges may in reality be a series of embedded box culverts.

Even though fords are low profile crossings, they can be and often are barriers to aquatic species. For example, they may be:

- Low-flow barriers because of insufficient water depth, if the ford is too wide at streambed elevation;
- Velocity barriers at moderate to high flows, if the floor of the ford lacks sufficient roughness;
- Jump barriers, if perches have developed in the channel as a geomorphic adjustment to the flow acceleration across the smooth surface.

Given the core objective, the inventory should include at least a qualitative evaluation of passage at fords. The FishXing software does not address low-water crossings, except for the culvert of a vented ford. True fords can be hydraulically modeled by using open-channel flow models, but usually low-water crossings will require field observations to determine with confidence whether aquatic species can pass at the relevant times of year. The field-form instructions indicate which measurements may pertain to fords and how they are taken.

4. What hydraulic assessment tool(s) will be used to evaluate crossings' barrier category?

FishXing is the preferred software for assessing fish passage at culverts because it not only models flow conditions over a range of flows throughout the length of the structure, but it also compares those flow conditions to the swimming and leaping abilities of fish species and life stages for which information is available. The results identify the type and location of migration barriers. FishXing is public domain software, well documented and able to handle many culvert situations (see section V. B. for FishXing limitations). This inventory protocol is designed to produce the data needed

to analyze passage using FishXing. If another hydraulic model will be used (such as HEC-RAS), additional input data are required.

5. What other issues besides aquatic animal passage will be addressed in conjunction with the passage inventory?

Several issues other than those related to aquatic species could be addressed in the crossing inventory, and they should be considered in setting improvement priorities. For instance:

- Flood conveyance capacity (to ensure that crossings are sized to handle the design flood);
- Crossing condition and maintenance needs; and
- Crossing failure risk and consequences of failure. An undersized culvert in a steep stream moving large amounts of woody debris might be ranked higher as a replacement priority because of its potential for plugging. It would rate even higher if it has a high fill, has a high risk of failing and could damage downstream aquatic habitat if it fails in a flood.
- Passage status for terrestrial wildlife that habitually use riparian areas for movement.

This procedure includes data needed for flood conveyance capacity and requires some observations of crossing condition and maintenance. Only some simple components of a failure risk and consequences assessment are included here. The reason is that a full assessment of failure risk and consequences must be based on an understanding of geomorphic processes throughout the watershed. In addition, the set of crossings where failure would cause serious consequences to downstream resources is likely to be different from (although it may substantially overlap) those that affect aquatic species passage. For these reasons, combining inventories would increase the amount of time and effort needed, which does not mean the two should not be coordinated when feasible and efficient. For background information on designing a failure risk and consequences assessment, see Flanagan and others (1998).

The habits of terrestrial animals should be considered when evaluating crossings. While salamanders swim or crawl in shallow-water margins and between rocks and logs, some terrestrial animals seem to prefer to keep their feet dry. The latter may prefer to climb up and over the fill, even if they can walk through a culvert. This may be fine on a low volume road, but undesirable on high traffic roads, where jersey barriers are placed at the road edge, or where the fill is very high.

III. FIELD WORK PREPARATION

A. Locating the crossings to be inventoried

After the objectives, scope, and analysis species are defined, the next step is to locate the set of crossings to assess in the inventory area. You might include all crossings in the area, but more likely it will be a subset based on your objectives and the resources available.

To identify the subset of crossings that affect the analysis species, overlay maps of their distributions on a **reliable** map of road-stream intersections. Geographical information systems (GIS) can be used to locate these intersections, but **only** if the road and stream layers are sufficiently reliable. Users are cautioned to have a clear understanding of the accuracy of any GIS layers they use. Check the GIS road layer against aerial photos, digital ortho-photographs, or satellite imagery to determine if some roads were missed or were not correctly located.

Species distribution information may be available from several sources, such as State and Federal agencies, Tribal governments, commercial landowners or non-profit organizations. It should be remembered that surveys for species presence have not always included smaller streams. Species distribution maps may show a species is absent on small streams, but this is not necessarily true, and it is a good practice to check species presence up-stream during the crossing inventory. If no species presence information is available, then it may be possible to estimate distribution using criteria developed from areas which have been surveyed. For instance, many units in the Pacific Northwest have assumed that fish do not occur above stream gradients of 20 percent, and have not conducted passage inventories on crossings on steeper streams. If you do this, **be aware** that: 1) your assumptions about habitat preferences may be incorrect, and 2) the topographic or other data used to screen out some crossings may be inaccurate or low resolution. Experience in the Pacific Northwest shows that fish are often in areas where biologists did not expect to find them. Note also that not finding fish in one sampling event does not necessarily mean they do not use the habitat at some time during the year.

It will be difficult to prioritize crossing restoration or determine where to begin and end crossing surveys if species distribution information is not available. Wherever possible a species inventory should accompany a crossing inventory when species distribution information is unknown or cannot be reliably predicted.

A final concern in identifying the subset of crossings to be assessed is land ownership. As noted above, in areas of multiple land ownership, the owner or road maintenance agency should be identified for each crossing. Make sure each landowner has been contacted and ensure you have permission to access the crossings on the dates of the inventory.

B. Keeping track of the crossings

All National Forest system crossings should be identified by the INFRA control number if the crossing is already entered in INFRA. However, the inventory will usually include unclassified or unnumbered roads, and a naming or numbering scheme needs to be developed so that each crossing has a unique identifier. Because crossings missed on the maps are frequently found in the field, having a contingency plan for numbering these missed crossings is advisable. For example, all crossings might be numbered consecutively as they are inventoried. Labels identifying watershed or district or some other logical division so that the field forms can be easily sorted by watershed are also a good idea. A field map should be maintained with all the site locations and numbers.

IV. THE INVENTORY

A. Reviewing office information

Already completed broad-scale planning and assessment documents (watershed and road analyses, road-management plans) may include guidance for future management of the road or watershed to be inventoried. These should be identified and reviewed.

Page 7 of the inventory form includes information on the location of other crossings on the same stream, their barrier category, and the extent of blocked habitat upstream. These data provide context for future project planning. If any of this is unknown, you may want to gather this information during the crossing inventory to facilitate prioritization.

B. Collecting the necessary equipment

Use this list (modified from Taylor and Love, 2002) to be sure you have the equipment you need:

- Maps with site locations.
- GPS unit.
- Self-leveling level and tripod, acceptable instruments depend on the site characteristics (see discussion above).
- Tapes (two): 300 ft and 100 ft in 1/10 ft increments.
- Clamps (to secure tapes for longitudinal profiles and cross-section surveys).
- Leveling rod: 25 ft in 1/100 ft increments.
- Pocket leveling rod (to measure breaks-in-slopes within smaller diameter culverts).
- Camera, film, and extra batteries.
- Compass.
- Waders, hip boots, and wading shoes (felt-soled).
- Safety vests if working on road with traffic.
- Hardhat.
- Flashlight or headlamp.
- First-aid kit.

Optional Equipment:

- Brush-clearing tools.
- Traffic cones.

C. Training the field crew

Crews must consist of at least two people, although three would be ideal. Higher production rates are obtained with a three-person crew, but more importantly, there is a third person to help explore the details of the site and bring additional skills to the team. Expect to spend one to two hours surveying each crossing, depending on the difficulty of the survey and the experience of the crew. Productivity will depend largely on travel time.

Since this inventory procedure brings several very different scientific fields together for one task, there is a great opportunity to forge partnerships across disciplines working in the same administrative unit. Ideally, the

inventory team will be interdisciplinary and include crewmembers with fisheries, hydrology/geomorphology and engineering survey experience. Each of these disciplines brings important skills to the survey. Fisheries biologists can evaluate species habitat use, hydrologists or geomorphologists have expertise in river mechanics and stream behavior, and engineers are best qualified to accurately survey the terrain. Field crews can become familiar with the protocols by participating in a training session, and by conducting test runs at specific sites to compare results and discuss the methods. Results from several teams can then be used to test measurement repeatability.

A survey crew should be ready to begin the inventory after hands-on training by experienced personnel. Instruction should include techniques in surveying profiles and cross-sections using an instrument at least as accurate as a surveyor's self-leveling level. Training should also include how to determine what points to survey in order to accurately measure the topographic points essential to categorizing crossing status. Note that hand instruments such as hand levels, clinometers and abney hand levels do not possess the accuracy necessary for this survey. Use of a higher order of hand instrument such as a Rhodes Arc would also be questionable depending on site conditions. Acceptable instruments depend on site characteristics (such as, slope, site complexity, and need for turning points). The flatter the slope and the more complex the site, the more accuracy is needed.

D. Conducting field work

Fieldwork consists of visiting each crossing and collecting the physical measurements needed to assess passage. The protocol also includes notes, site sketches, and photographs describing the type and condition of each crossing structure and illustrating adjacent channel and habitat conditions. The inventory procedure is primarily designed to identify culverts that obstruct or delay movement of one or more species and life stages. Pertinent measurements and observations should also be taken for fords, unless the inventory objectives exclude them.

Data sheets and instructions for the crossing inventory are located in Appendix E. It is a good practice to regularly photocopy data sheets to provide back-ups, and to regularly enter data into electronic databases so that mistakes or missed data can be quickly noticed and corrected.

E. Ensuring safe procedures

A job hazard analysis (JHA) is required before the inventory begins (see example in Appendix D). Each crewmember should review the analysis during training and in weekly safety meetings.

Use proper safety equipment and carefully assess the specific characteristics of each crossing before conducting surveys. If the survey is being conducted on a road open to traffic, consider placing signs (such as "Survey Party") to announce your presence to oncoming traffic from both directions. Crewmembers should also wear bright orange vests to increase visibility. Two-way radios provide effective communication between crew members in spite of noise from road traffic and stream flow (Taylor and Love 2002).

Note: Field forms and instruction can be found in Appendix E.

V. PASSAGE ASSESSMENT

A. Developing the regional passage screen

1. Introduction

The assessment begins with a determination of whether the crossing resembles the adjacent natural channel. The top box in Figure V-1 lists specific criteria used to make this determination. The criteria are intended to distinguish crossings that allow a wide variety of species to pass the crossing including: amphibians, reptiles, some invertebrates, and numerous species and life stages of fish. They are based on the presumption that if the culvert physically resembles the adjacent channel, then flow and substrate conditions within the culvert will be similar enough to allow passage at the same times animals are moving in the natural channel. If a species has a critical movement window of only a few days, and this happens to coincide with above-bankfull flows in a specific year, these criteria would not assure passage.

When crossings do not resemble the natural channel they are taken to the next step in the screen. In this step, the crossing is compared to regionally or locally developed screen criteria that specifically address the passage needs of the analysis species. Examples of these screens are shown in Figures V-2 and V-4. The screening procedure is designed to quickly classify crossings into passage categories for each analysis species, species group, or lifestage.

The screen will not cover all possible scenarios. Some crossings have characteristics that may hinder passage but are not included in the screen—for example, debris or sediment blockages, debris screens and trash racks, and drop-inlets. We recommend using the screen criteria to categorize the crossing before leaving the site to permit the field crew to validate the result based on their observations.

FishXing would be used when the result of the screen places the crossing in the “indeterminate” category (that is, when screen criteria can not determine whether the crossing conditions are adequate or inadequate). There are some situations, such as culverts with baffles, weirs or other fishways, where the crossing category cannot be determined by either the regional screens or FishXing. These situations require field monitoring or detailed mathematical modeling.

Figure V-1. Passage assessment process

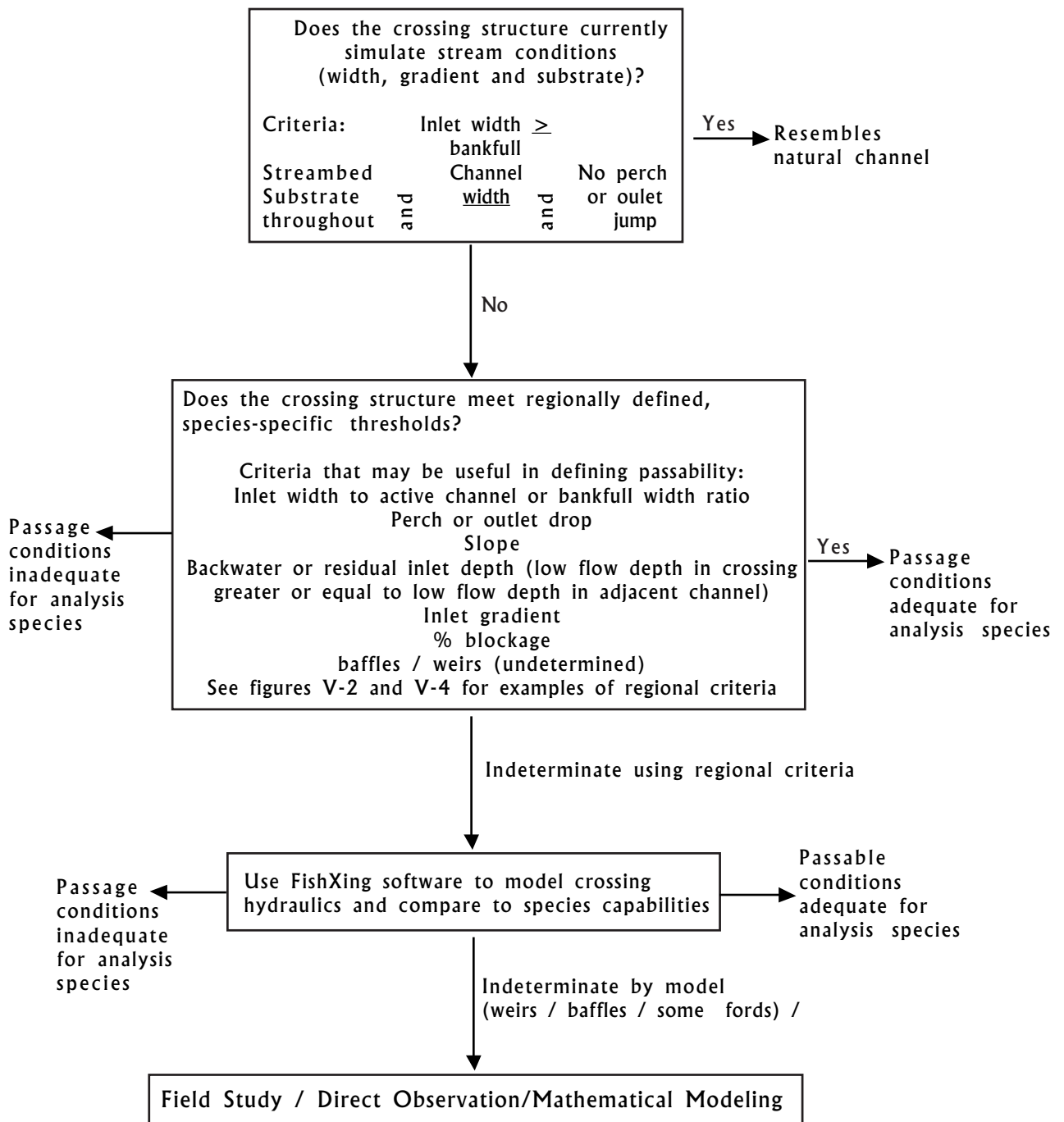

2. Screen Criteria

a) Crossings that resemble the natural channel

Characteristics that indicate that the crossing resembles the natural adjacent channel include:

- Streambed substrate is continuous throughout the crossing and the streambed slope, particle size and arrangement are similar to the adjacent channel;
- The crossing does not constrict the bankfull channel width. To meet this criterion, the inlet width must at least match the natural channel bankfull width, usually measured upstream of the structure and away from its zone of influence.

Note that these criteria are not necessarily the ones that would be used to design 'stream simulation' crossings.

Streambed substrate continuity—For crossings to resemble the natural channel, they must be able to transport all watershed products moving in the stream channel at least up to bankfull flow. Where this goal is met, bed material size, arrangement, and slope profile inside the structure are either similar to the adjacent channel sections, or they are designed to provide a similar rate of energy loss. In the field, evidence of similarity in embedded structures that have been in place for several years is: lack of bedload or debris accumulation upstream of the structure (caused by the structure), lack of downstream scour, and low flow depths similar to those in the natural channel. Upstream of the structure, look for unusual bank erosion, and for finer bed material and lower slopes than in adjacent sections (evidence of aggradation). Downstream, look for abrupt slope changes and larger bed material (evidence of degradation). Keep in mind that nearby tributaries can modify streambed particle sizes as well. Also keep in mind the age of the structure. If it is new, the channel may still be adjusting to installation, so determining whether the crossing will function like the adjacent natural channel may not be possible.

On slopes lower than about 3 percent, bed material size, arrangement and slope profile in the structure are expected to be identical to the nearby stream sections. On higher slopes, bed material may be larger than in the natural channel, in order to resist movement during larger than bankfull flows. To qualify in this category, however, the bed material must be arranged into stable bedforms that provide for flow diversity, energy dissipation, and continuity of bedload transport through the structure. For the purposes of this inventory, it is recommended that crews rely on the observations outlined above to make that determination.

Bankfull channel width—Compare the average of the adjacent bankfull channel widths recorded on page four of the field form to the width of the structure opening. Where channel types differ above and below the crossing, you will need to judge which width should be matched. Bedslope, bedforms, and width must all work together to maintain continuity of transport through the reach.

Regional adjustment of these criteria for natural channel resemblance will probably not be required.

b) Fishways: baffles and weirs

Many culverts have been modified or retrofit with baffles or weirs for fish passage. Baffles and weirs typically act to reduce velocities, provide resting pools, and consolidate low flows to provide more suitable depth. These structures are sometimes installed to retain streambed material inside the pipe. Where these are completely embedded the crossing can be considered to have continuous substrate. Baffled culverts that are not completely embedded are not easy to screen because the hydraulics can be complicated—even unsolvable. Many baffled culverts require field study to determine their passage category and are initially put in the ‘indeterminate’ category.

c) Regionally defined analysis species criteria

If the structure does not simulate the natural channel, then continue through the portion of the flow chart (Figure V-1) that includes the regionally developed analysis species criteria. Regional analysis species criteria are thresholds that reflect the species, life stage, or species group’s ability to swim through or leap into crossing structures. If a culvert meets the regional analysis species criteria, then the passage conditions are categorized as adequate. If the regional criteria are not met, then either passage is inadequate or indeterminate using the screen. If it is indeterminate, then other analyses (eg. FishXing, monitoring) are needed.

The screening procedure should quickly classify crossings into one of four categories:

- Crossing resembles adjacent channel: passage assumed for aquatic species
- Meets criteria: passage conditions are adequate for the analysis species for which the screen is designed
- Fails criteria: passage conditions are inadequate for the analysis species for which the screen is designed
- Indeterminate barrier category: requires hydraulic or other analysis.

These barrier categories are species specific, so it is possible for a crossing to be in more than one category (eg. adequate for adults, indeterminate for juveniles).

The benefit of developing regional screens is that they speed up the process of categorizing many crossings. Where we can define certain observable characteristics (such as perch height) that make a crossing impassable for most individuals of the analysis species, this method is more efficient than hydraulic analysis. The risk, of course, is that we may not have all the information to select solid criteria, and so best professional judgment must frequently be used. Thus we are always at some risk of placing crossings in the wrong category.

It is important to remember that barrier determination is not an exact science. As with all biological characteristics, a range in swim performance is found when individuals are tested. Also, field conditions may vary considerably from those in a laboratory where much of the swim performance data are gathered. Swim performance data should be considered as a guidepost and you must use judgment to construct the screens.

If the screen criteria are based on the lowest numbers in the range reported for swim or leap performance for the analysis species, then some of the crossings will be placed in the “passage condition inadequate” category when they are actually passable to most individuals. If the criteria are based on the upper end of the range, then more crossings will fall in the “indeterminate” category, requiring the use of the hydraulic model. Inventory, analysis, and repair of culverts are expensive, and restoration dollars are limited. It is, therefore, important to consider the consequences of choosing criteria from various portions of the swim performance ranges reported in the literature. It is our recommendation that screens be tested on a sample of crossings that cover the full range of categories. A group of experienced professionals should be familiar with the test crossings and agree about their category. Testing will help to make sure the screens are performing as expected.

At least three screens have been developed to identify fish-passable crossings without a hydraulic analysis. Two are described here as examples, along with some discussion of the logic behind the criteria. Each of these screens is the result of substantial experience in assessing culverts for salmonid passage. **The examples presented here** may not be appropriate outside the regions for which they were developed. Remember that these screens were developed by regional teams representing agencies and organizations with interest in **fish** passage. If passage for non-fish species is important in your area, you may develop several screens for a broader range of analysis species. Regional screen development teams should include fish and wildlife management agencies and road managers of all jurisdictions. If this is done, barrier determinations will rest on a consensus definition that meets legal standards, and the data can be aggregated across the various ownerships in a watershed. Certainly, decisions about variables and values within any regional screen should be justified and documented.

The screen referred to above, but not presented here as an example, is included in the Washington Department of Fish and Wildlife’s Fish Passage Barrier and Surface Water Diversion Screening Assessment and Prioritization Manual, August 2000. See page 17 at www.wa.gov/wdfw/hab/engineer/fishbarr.htm.

Example 1: California’s first-phase passage evaluation filter

The flowchart screen (Figure V-2) is from Taylor and Love (2002). It is designed to cover both adult and juvenile anadromous salmonids. It puts crossings into three categories: red, gray, and green. Definitions in this scheme are as follows:

- Green: Conditions are assumed adequate for passage of all salmonids. Even the weakest swimming lifestage (juveniles) can pass the crossing during the entire period of migration.
- Gray: Conditions may not be adequate for all salmonid species or life stages presumed present. Additional analyses are required to determine extent of the barrier for each species and lifestage.
- Red: Conditions do not meet passage criteria over the entire range of migration flows for even the strongest swimming species and lifestage (adults) presumed present. Assume ‘passage condition inadequate’.

The crossings that resemble the adjacent natural channel are categorized as green (see the left-hand side of this screen). They have streambed substrate

throughout and inlets as wide as the active channel. If either one of those criteria are not met, a crossing can still be considered “green”, but only when its entire length is backwatered at extreme low flows (see Figure E-14 for illustration of ‘residual inlet depth’). These criteria are designed so that even the weakest lifestage can pass a green crossing. Criteria leading to a red call are an outlet drop of 2 feet or greater, or a steep slope without baffles or weirs to modify velocity and depth. Other crossings are partial or unknown barriers, and the barrier category is undefined until hydraulic analysis is completed.

In this screen, the values assigned to critical variables are conservative, to accommodate passage by weaker-swimming individuals. Stronger (larger) individual fish can often pass successfully upstream through a red culvert under certain flows. The values also incorporate current National Marine Fisheries Service guidelines and California Department of Fish and Game design standards.

A benefit of using a flow-chart model is that values of specific variables can be easily changed to judge the sensitivity of the model to data sets. But because the California model covers all crossing structure types with one set of criteria, it does not allow the user to distinguish crossings that may permit easier passage than others (for example, larger corrugations on metal pipes). The California flowchart also includes all species of concern (namely, adult and juvenile coho salmon) in one flow chart, which results in a number of gray culverts. It would be possible to reduce the number of gray culverts and the required additional analysis by constructing two flowcharts, one for adult and one for juvenile fish. With two flowcharts many culverts would probably be red for juveniles (needing no more additional analysis) and gray for adults (needing additional analysis with FishXing).

For regional teams wanting to use the flow-chart model to develop regional species or species-group criteria for an initial screen, we have included a fill-in-the-blank version in Appendix B. Brief explanations of the criteria are included there. Note that the example variables may or may not be appropriate for all species. Other types of information may be required for passage of amphibians, reptiles, invertebrates, or small mammals.

Example 2: Alaska’s initial screen

The screening matrix developed in Alaska (by a group comprising USFS Region 10, the Alaska Department of Fish and Game, Alaska Department of Transportation, the Environmental Protection Agency, and the FishXing development team) is for juvenile coho salmon only. It is applied for juveniles of all species in southeast Alaska (Figure V-4). This matrix explicitly recognizes the mix of characteristics that, if present together, permit passage for juvenile fish through the various listed crossing types. Building a detailed matrix like this one obviously requires considerable information on the movement of the analysis species and direct experience observing movement through many different crossing structure types. Note that crossings passable by adult but not juvenile fish are red, unlike in California where they would be gray.

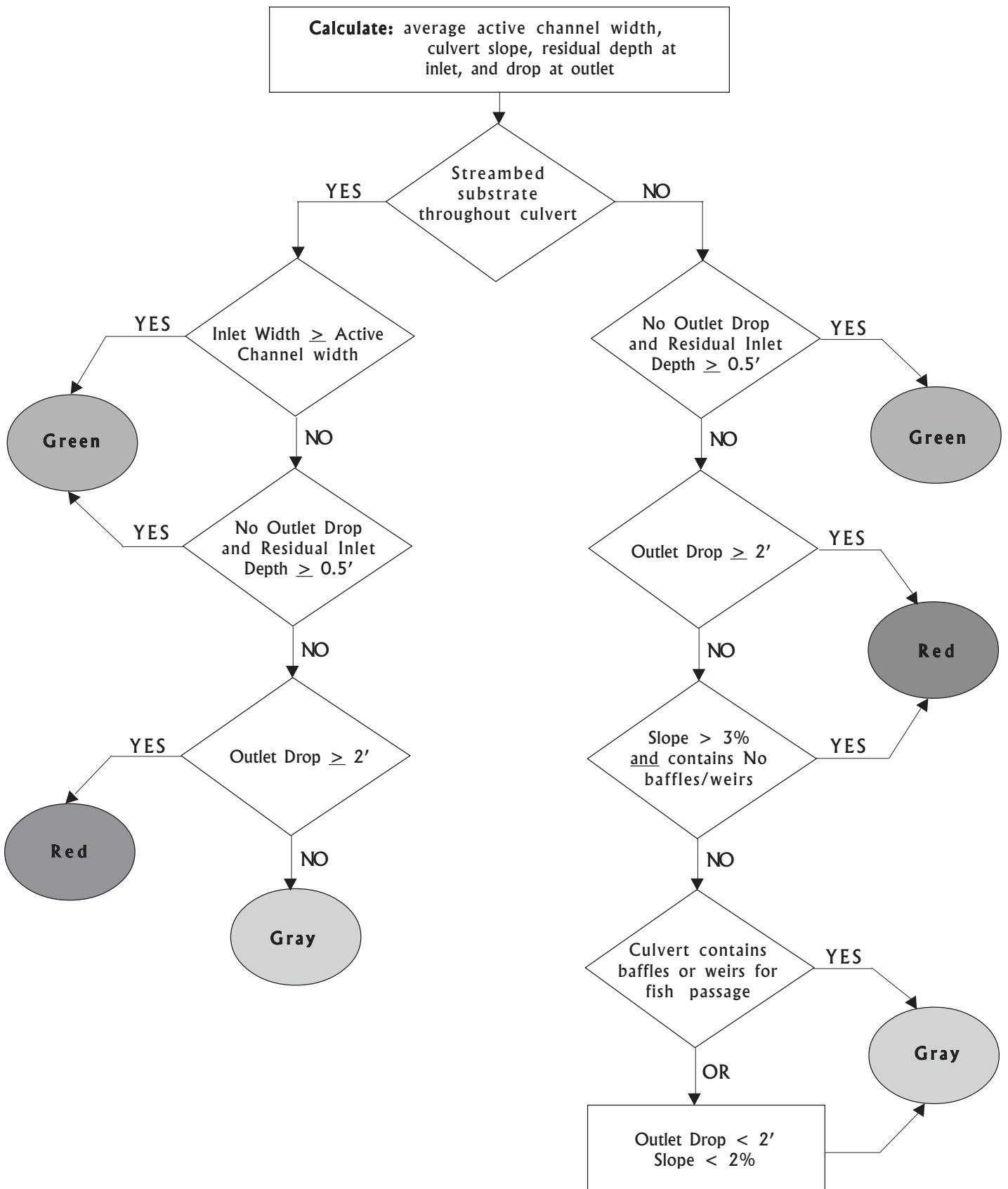

Figure V-2. EXAMPLE ONLY: Green-Gray-Red screen developed for California's anadromous adult and juvenile salmonids (Taylor and Love 2002).

Example Only

Figure V-3. Alaska fish-passage evaluation criteria (juvenile coho) USDA Forest Service Region 10

	Structure	Green ¹	Gray ²	Red ³
1	Bottomless pipe arch or countersunk pipe arch, substrate 100% coverage and invert depth greater than 20% of culvert rise.	Installed at channel grade (+/- 1%), culvert span to bedwidth ratio of 0.9 to 1.0, no blockage.	Installed at channel grade (+/- 1%), culvert span to bedwidth ratio of 0.5 to 0.9, less than or equal to 10% blockage.	Not installed at channel grade (+/- 1%), culvert span to bedwidth ratio less than 0.5, greater than 10% blockage.
2	Countersunk pipe arches (1x3 corrugation and larger). Substrate less than 100% coverage or invert depth less than 20% of culvert rise.	Grade less than 0.5%, no perch, no blockage, culvert span to bedwidth ratio greater than 0.75.	Grade between 0.5 to 2.0%, less than 4" perch, less than or equal to 10% blockage, culvert span to bedwidth ratio of 0.5 to 0.75.	Grade greater than 2.0%, greater than 4" perch, greater than 10% blockage, culvert span to bedwidth ratio less than 0.5.
3	Circular CMP 48 inch span and smaller, spiral corrugations, regardless of substrate coverage.	Culvert gradient less than 0.5%, no perch, no blockage, culvert span to bedwidth ratio greater than 0.75	Culvert gradient 0.5 to 1.0%, perch less than 4 inches, less than or equal to 10% blockage, culvert span to bedwidth ratio of 0.5 to 0.75.	Culvert gradient greater than 1.0%, perch greater than 4 inches, blockage greater than 10%, span to bedwidth ratio less than 0.5.
4	Circular CMPs with annular corrugations larger than 1x3 and 1x3 spiral corrugations (>48" span), substrate less than 100% coverage or invert depth less than 20% culvert rise.	Grade less than 0.5%, no perch, no blockage, culvert span to bedwidth ratio greater than 0.75.	Grade between 0.5 to 2.0%, less than 4" perch, less than or equal to 10% blockage, culvert span to bedwidth ratio of 0.5 to 0.75.	Grade greater than 2.0%, greater than 4" perch, greater than 10% blockage, culvert span to bedwidth ratio less than 0.5.
5	Circular CMPs with 1x3 or smaller annular corrugations (all spans) and 1x3 spiral corrugations (>48" span), 100% substrate coverage and substrate depth greater than 20% of culvert rise.	Grade less than 1%, no perch, no blockage, culvert span to bedwidth ratio greater than 0.75	Grade 1.0 to 3.0%, perch less than 4 inches, less than or equal to 10% blockage, culvert span to bedwidth ratio of 0.5 to 0.75.	Culvert gradient greater than 3.0%, perch greater than 4 inches, blockage greater than 10%, culvert span to bedwidth ratio less than 0.5.
6	Circular CMPs with 2x6 annular corrugations (all spans), 100% substrate coverage and substrate depth greater than 20% of culvert rise.	Grade less than 2.0%, no perch, no blockage, culvert span to bedwidth ratio greater than 0.75	Grade 2.0 to 4.0%, less than 4" perch, less than or equal to 10% blockage, culvert span to bedwidth ratio of 0.5 to 0.75.	Grade greater than 4.0%, greater than 4 inch perch, greater than 10% blockage, culvert span to bedwidth ratio less than 0.5.
7	Baffled or multiple structure installations	All	All	
8	Log stringer or modular bridge	No encroachment on bedwidth.	Encroachment on bedwidth (either streambank).	Structural collapse.

Note: Larger corrugations increase roughness allowing for fish passage at steeper culvert gradients.

¹Green – Conditions at the crossing are assumed adequate for fish passage

²Gray – Conditions at the crossing may not be adequate for fish passage, additional analysis required.

³Red – Conditions at the crossing are assumed to be not adequate for fish passage, additional fieldwork and analysis required.

B. Conducting hydraulic analysis

When the status of a crossing cannot be determined by applying the regional screens, hydraulic modeling can often be used to determine if the crossing has adequate passage characteristics for the analysis species.

1. Flow selection

Hydraulic models require the user to select the pertinent flows. Designing road crossings to pass fish at all flows is impractical (NMFS 2000; Robison and others, 2000; WDFW SSHEAR 1998). Most aquatic species take refuge during larger flood events. Conversely, during low flow periods shallow water depths in many small streams can make the channel itself impassable. Generally there will be an upper and a lower flow threshold beyond which passage need not be accommodated. In some areas, fish management or regulatory agencies have defined the range of flows where movement must be accommodated (See appendix C).

2. Swim Performance

The field data needed to support the FishXing software are gathered during this inventory. FishXing is available on line at www.stream.fs.fed.us/fishxing. The current version (2.2) calculates velocities and depths throughout the pipe for a specific flow and then compares them to default or user-input values for fish swim speeds and depth requirements. The default values should not be assumed appropriate across regions. Developing a regional model should include selecting user-input values for swimming ability. The program identifies the locations of velocity and lack-of-depth barriers in the pipe, and the jump height barriers at perched outlets.

3. Fish Crossing Limitations

FishXing models a limited set of the most common culvert shapes. It does not model complex crossing structures such as multiple pipes, aprons, fords or culverts with internal grade breaks, (although multiple runs can sometimes simulate this condition). The software calculates a composite roughness value for pipe bed and walls at each node in the pipe (about every 3 feet) based on water depth (the solution is iterative because depth and composite roughness are interdependent variables). FishXing assumes that embedded and open bottom culverts have flat homogeneous beds. This frequently results in a “passage condition inadequate” determination, because true low flow depth is underestimated. For this reason, FishXing should be used with extreme care, if at all, when there is continuous streambed material through the crossing structure.

Other hydraulic evaluation models include CulvertMaster (<http://www.haestad.com>), the Federal Highways Culvert program HY-8 and HEC-RAS. The Federal Highway Administration Bridge Technology website <http://www.fhwa.dot.gov/bridge/hydssoft.htm> includes links to several of these software packages. These models do not incorporate the swim performance information that FishXing offers, and additional calculations comparing fish swim performance to the hydraulic properties in the pipe are required.

C. Summarizing crossing category for analysis species

Some crossings block all species and life stages at all flows, others block some species and life stages only at certain flows, and still others block some species and life stages at all flows. These characteristics can be crucial for prioritizing passage restoration projects. While it is tempting to describe crossings as “partial” or “total” barriers, the meaning of these terms has not

been standardized. Important information is lost when these terms are used; for example: what does partial mean? Is it a barrier some of the time for all species present, or all of the time for some of the species present? Because these terms are vague and easily misinterpreted, we recommend that summaries be limited to tables that list the analysis species and its crossing category from the screening process (such as, passage condition adequate, passage conditions inadequate, indeterminate). Consistent use of these terms by units using this protocol will permit information exchange and prioritization across units and jurisdictions. [The meanings of these terms are essentially the same as the green, red, and grey used by previous inventory protocols. Each protocol uses different regional criteria to define green, grey and red, just as different geographic regions will need to use different criteria to define adequate, inadequate and indeterminate.]

VI. PRIORITIZATION OF ROAD CROSSING TREATMENTS

A. Establishing the larger watershed context

Stream restoration projects, such as removing passage barriers, are most effective when they are planned and priorities are set based on an understanding of the watershed's condition, use by resident biota, its production potential, and its relation to the larger basin. For example, two streams similar in size and type of barrier problems could have very different priorities if one is tributary to an area of high fish production, while the other is not. To fully understand passage restoration needs in a drainage system, we need to understand the ecology of the local biota. What role does the blocked area play in the life history of individual animals, and in the structure and dynamics of populations or communities? What are the biological consequences of not restoring passage? The nature and importance of ecological consequences of a barrier is the standard against which passage restoration costs must be weighed. An understanding of the other restoration needs within the watershed is also crucial. For example, fixing passage barriers may be less important if water or habitat quality is low. A watershed approach (McCammon et al 1998) should be taken to ensure that priorities are set based on a full assessment of watershed conditions, not on a limited site-scale view.

Where transportation plans are completed, they are an important part of establishing the context for restoration. The long term plans for the road can inform decisions about whether or not to restore passage at the culvert. It may be that the road is planned for removal or upgrade; if so, passage issues can be addressed when the removal or upgrades are done.

B. Protecting areas from invasive species

Before any treatment planning starts, consider these questions: Are exotic invasive species present in the area? Should barriers be maintained? In freshwater ecosystems, non-native invasions are one the primary causes of species extirpations and population declines (Miller and others 1998, Allan and Flecker 1993). Crossings sometimes inhibit upstream spread of non-native or undesirable species. However, if exclusion is truly desired, an obstruction should be designed to keep the specific invader from moving upstream. Crossings often function as incomplete barriers to upstream movement. Passage may be possible during certain infrequent flow events, or larger individuals may be able to pass at some flows. Also, while it may be possible to protect a native species by retaining a crossing barrier, this may also have the undesirable effect of increasing that population's extinction probability. Barriers can prevent re-colonization of the upstream reaches after catastrophic disturbances (Brown 1986, Frissell 1993, Angermeier 1995). The tradeoffs related to improving access at road crossings when non-native species are present should be very carefully considered.

C. Developing a scheme for setting priorities

This discussion relies heavily on Taylor and Love (2002).

Because sufficient funding in any one fiscal year to correct all passage problems is unlikely, setting priorities is usually necessary. Some federal, state and local agencies, tribes, and watershed councils may already have developed methods for setting priorities based on local issues and species needs. If your local area does not already have a plan, what follows can help you and your partners develop a method that ranks road-crossing treatments by whatever combination of criteria is most critical.

When you develop your scheme for ranking treatment of road crossings consider the following:

- Quantity and quality of upstream and downstream habitat that would be made accessible.
Example 1: A somewhat shorter but higher quality habitat may be more important to open up than a lower quality, but longer, habitat area.
Example 2: Seasonal water-quality problems may increase the importance of ensuring access between stream sections because aquatic species' survival may depend on their ability to move in response to seasonal changes in water quality. For example, juvenile salmonids may need to move to cooler tributaries when mainstream channel temperatures rise in summer.
- Species status
Passage problems affecting ESA-listed species should rank higher than those affecting species not currently imperiled.
- Crossing failure risk
Potential adverse effects to aquatic systems will be avoided by replacing crossings at high risk of failing because they are undersized or in poor condition.
- Presence of upstream and downstream barriers (movement requirements vary by species and life stage).
Example 1: For anadromous fish species, the presence of other barriers downstream is an important issue because their survival depends on having accessible stream corridors from the ocean to upstream spawning grounds. Fixing upstream barriers is less productive when downstream barriers are still in place. Effective treatments generally proceed in an upstream direction.
Example 2: For resident species, individuals need to move in both directions to avoid predators, find mates or food, or reduce competition for local resources.
- Habitat use
Opening corridors to high quality habitat may be more important than fixing barriers across several drainages.
- Extent to which the barrier blocks native or desirable aquatic species, or alters native biological diversity.
Removing a total barrier will assist more species and life stages than removing a partial barrier, and so may be more effective in re-establishing the native biological community. Also, restoration of access in areas where native biological diversity is intact may have higher priority than an area where native biodiversity has already been compromised.
When considering which species are excluded, considering the role of barriers in preventing exotic species invasion.

- Known barriers.
Restoring passage where attempts to pass frequently fail and where predators or poachers congregate to take advantage of the blocked animals may be more important than other places. These sites also have a high probability of fostering immediate recolonization of upstream habitat.

The objective of setting priorities is to assess the biological risks and consequences of crossing barriers and to rank them in order of importance for passage restoration. Naturally, other factors—such as social, economic, or scheduling efficiencies—will enter into the actual scheduling of treatments. For example, equipment move-in costs may make addressing all barriers on a particular road system at the same time more economical, even though some of the crossings are of low biological priority.

Schemes for setting priorities can be simple or complex depending on your local capabilities and needs. Keep the scheme as simple and clear as possible for consistent application so that your prioritization decisions can be easily explained. An example scheme slightly modified from one being developed in California is shown in Appendix A.

D. Finding sources of habitat quality and quantity information

Information about habitat upstream and downstream of culvert locations can be obtained from previously conducted habitat typing or population surveys. Habitat information is often available in reports on file at state Fish and Wildlife agencies, federal (FS, BLM, EPA), or tribal offices. Private sector biologists, watershed groups, coordinators, restorationists, and large landowners can assist in acquiring additional information on drainages in their jurisdictions.

Information on habitat quality throughout the watershed is needed to provide a watershed-scale context for each barrier culvert. Some examples:

- Certain blocked areas may be able to provide high-quality winter rearing in a watershed where that type of habitat is critically short;
- The area downstream of a crossing with a high risk of failure in a flood might be extraordinary habitat for an endangered species; and
- A barrier culvert may be protecting an endangered amphibian from predation by introduced fish.

Quantitative field assessments of habitat quality are desirable, but if none are available then other types of information can be used as indicators of habitat quality. Examples include disturbance indicators available on GIS coverages, such as the percentage of watershed area in young vegetative stands (recently harvested), road density, riparian area grazing density, mining disturbance acres, and the amount of impervious surface or urbanization. Note that these indicators are much less reliable than habitat quality variables measured or even estimated in the field. Their relation to habitat quality is frequently indirect, and real habitat quality may or may not reflect the assumed relations. At a minimum, we recommend that a fisheries biologist or aquatic scientist look at the stream to estimate its quality.

Summer water-temperature or other water quality data are helpful in identifying tributaries that may provide high quality habitat. Knowledge about water quality can help to identify water-quality refuges and non-structural impediments to movement from poor quality to higher quality habitats. Such movements are often key to the growth and survival of aquatic organisms. This information may be available from state environmental agencies for streams listed on 303(d) lists as having beneficial use impairment (such as, temperatures outside natural regime, low dissolved oxygen, elevated toxins).

NOTE: Field forms and instructions are located in Appendix E.

VII. REFERENCES

Allan J. D., and A. S. Flecker. (1993) *Biodiversity conservation in running waters*. Bioscience 43:32-43.

Angermeier, P. L. (1995) *Ecological attributes of extinction-prone species: loss of freshwater fishes of Virginia*. Conservation Biology 9:143-158.

American Association of State Highway and Transportation Officials. (2000) *Standard Specifications for Transportation Materials and Methods of Sampling and Testing Part 1 – Specifications*. Twentieth edition. www.aashto.org

American Iron and Steel Institute. (1994) *Handbook of Steel Drainage & Highway Construction Products*. 1994. Fifth edition. AISI, Washington, DC.

Brown, K. L. (1986) *Population demographic and genetic structure of plains killifish from the Kansas and Arkansas River basins in Kansas*. Transactions of the American Fisheries Society 115:568-576.

Flanagan, S.A., M.J. Furniss, T.S. Ledwith, S. Thiesen, M. Love, K. Moore, and J. Ory. (1998) *Methods for Inventory and Environmental Risk Assessment of Road Drainage Crossings* USDA Forest Service Technology and Development Program, San Dimas, CA.

Frissell, C. A. (1993) *Topology of extinction and endangerment of native fishes in the Pacific Northwest and California (USA)*. Conservation Biology 7:342-354.

Harrelson, C.C., C.L. Rawlins, and J. P. Potyondy. (1994) *Stream Channel Reference Sites: an Illustrated Guide to Field Technique*. USDA FS GTR RM-245, Rocky Mountain Forest and Range Experiment Station, Ft Collins, CO. 61 p.

McCammom, B., J. Rector, and K. Gebhardt. (1998) *A Framework for Analyzing the Hydrologic Condition of Watersheds*. USDA-FS and USDI-BLM. BLM Technical Note 405.

Miller, R. R., J. D. Williams, and J. E. Williams. (1989) *Extinctions of North American fishes during the past century*. Fisheries 14:22-38.

Moser, M. (1999) *Low Light Impediments to Fish Migration with Particular Emphasis on River Herring*. Web Presentation of The CTE/NCDOT Research Forum. <http://carey078.itre.ncsu.edu/fishmigration.html>

Normann, J. M., R. J. Houghtalen and W. J. Johnston. (1985) *Hydraulic Design of Highway Culverts* Federal Highway Administration, Report No. FHWA-85-15. recently updated: FHWA NHI-01-020 (2001).

Robison, E.G., A. Mirati, and M. Allen. (June 1999) *Oregon Road/Stream Crossing Restoration Guide*, Advanced Fish Passage Training Version. www.nwr.noaa.gov/1salmon/salmesa/4ddocs/orfishps.htm.

Stream Systems Technology Center, Rocky Mountain Forest and Range Experiment Station, USDA-Forest Service. *A Guide to Field Identification of Bankfull Stage in the Western United States*. (video) www.stream.fs.fed.us.

Taylor, R. N., and Michael Love (August 2001) *Fish Passage Evaluation at Stream Crossings*. Prepared for California Dept of Fish and Game.

USDA—FS. (1998) WinXSPRO, A Channel Cross Section Analyzer, User's Manual. Prepared by West Consultants Inc. USDA—FS Rocky Mountain Experiment Station, Ft. Collins, CO.

USDA Forest Service. (1999) *Roads Analysis: Informing Decisions about Managing the National Forest Transportation System*. Misc. Report FS-643. Washington, DC. USDA Forest Service. 222 p.

USDA Forest Service, Region 6. Fish Passage through Road Crossings Assessment, with Explanations and Instructions. Unpublished report available through the USDA Forest Service Region 6 regional office.

USDA Forest Service, Region 10. (March 2001) Forest Service Handbook 7709.58—Transportation system maintenance handbook. Region 10, Supplement No. 7709.58-2000-1.

USDA Forest Service, Region 10. Tongass Fish Passage Protocol (Riparian Monitoring Question #3). Unpublished report available through the USDA Forest Service Region 10 regional office.

Warren, M. L., Jr, and M.G. Pardew. (1998) *Road Crossings as Barriers to Small Stream Fish Movement* in Trans Am Fisheries Soc 127:637-644.

Washington Dept of Fish and Wildlife Habitat Program, SSHEAR section. (August 2000) *Fish Passage Barrier and Surface Water Diversion Screening Assessment and Prioritization Manual*. <http://www.wa.gov/wdfw/hab/engineer/fishbarr.htm>.

APPENDIX A

EXAMPLE SCHEME FOR SETTING PRIORITIES— MODIFIED FROM THE CALIFORNIA METHOD

This ranking method is slightly generalized from a draft developed for California by Taylor and Love (2002); it is shown here with their permission. The original was devised primarily for coastal watersheds with potential habitat for anadromous salmonids. Some terminology has been modified to be consistent with this document, the emphasis on anadromous fish has been eliminated, and the extent-of-barrier variable has been simplified (2, below).

The ranking method assigns scores for the following parameters at each barrier crossing.

- 1. Species diversity** For each road crossing, add up ESA-listing status scores for each species known to be within the stream reach (now or historically). Score: Endangered = 3 points; Threatened = 2 points; not listed = 1 point Consult your local State Fish and Wildlife agency, USFWS, or NMFS for species distribution and listing status.
- 2. Extent of Barrier** For each species and lifestage of concern at the crossing, determine whether it is a total or partial (passable at some flows) barrier. Add the scores to get a total barrier extent score. Score: Total barrier for a species and lifestage= 2 points; partial barrier for a species and lifestage=1 point.
- 3. Habitat quantity** Score length in feet or meters above the road crossing to the limit of distribution of the analysis species. Score: We suggest starting at some agreed on minimum (such as, 500 ft); and assign 0.5 points for each size class unit (example: 0 points for <500 ft; 1 point for 1,000 ft; 2 points for 2,000 ft; and 5.5 points for 5,500 ft).
- 4. Habitat quality** Assign a habitat-quality score after reviewing available habitat information as follows.
 - **Score: 1.0 = Excellent.** Relatively undeveloped, “pristine” watershed conditions. Habitat features include dense riparian zones with mix of mature native species, frequent pools, high-quality spawning areas, high water quality, near natural water temperature regimes, complex in-channel habitat, channel floodplain relatively intact. High likelihood of no future human development. Presence of one or more migration barriers is obviously the watershed’s limiting factor.
 - **0.75 = Good.** Habitat is fairly intact, but human activities have altered the watershed, and that activity is likely to continue. Habitat still includes dense riparian zones of native species, frequent pools, spawning

gravels, good water quality, near- natural water temperature regimes, complex in-channel habitat, floodplain relatively intact. Presence of one or more migration barriers is most likely one of the watershed's primary limiting factors.

- **0.5 = Fair.** Human activities have altered the watershed. Expect continued or increased human activity that will continue to affect watershed processes and features. Habitat effects include riparian zone present that lacks mature vegetation and has non-native species, infrequent pools, sedimentation evident in spawning areas (pool tails and riffle crests). Water quality and water temperature regimes have been altered to the point that they periodically exceed stressful levels for analysis species. There is sparse in-channel complex habitat, floodplain intact or slightly modified. Presence of one or more migration barrier is probably one of the watershed's limiting factors (out of several factors).
- **0.25 = Poor.** Human activities have significantly altered the watershed with high likelihood of continued (or increased) activities, with apparent effects to watershed processes. Habitat effects include intact riparian zones absent or severely degraded, little or no pool formations, excessive sedimentation evident in spawning areas (pool tails and riffle crests), water-quality problems are stressful to lethal to analysis species, lack of in-channel habitat, floodplain severely modified with levees, riprap, and residential or commercial development. Other limiting factors in watershed most likely have higher priority for restoration than remediation of migration barriers.

5. Total habitat score Multiply the scores for habitat quality and habitat quantity for each blocked species of concern. Add all the species together to get the total score.

6. Sizing (risk of failure) Score each culvert according to the size of flow it was designed to accommodate. **Score:** sized for at least a 100-year flow at headwater/depth = **1**; sized for at least a 50-year flow = **2**; sized for at least a 25-year flow = **3**; sized for less than a 25-year flow = **4**; sized for less than a 10-year flow = **5**.

7. Current condition for each culvert, assign one of the following values. **Score:** good condition = **1**; fair (problems exist but are not likely to cause culvert to fail) = **2**; poor (problems could cause failure) = **3**.

For each road crossing, enter the scores into a spreadsheet and compute the total. Then, sort the list by "total score" to determine a first-cut ranking. Other sorts can be done to isolate certain kinds of crossing problems. For example, sites that have poor habitat quality may be sorted separately so that ranking at these sites can focus on culvert sizing and risk failure.

Additional Ranking Considerations

The results of the ranking matrix provide a rough, first-cut prioritized list of crossings requiring treatment. Other important factors will be considered when you decide the exact scheduling of remediation efforts.

On a site-specific basis, some or all of the following factors should be considered in refining the first-cut ranking.

1. Amount of road fill. At structures that are undersized or in poor condition, consider the volume of fill material in the road prism potentially deliverable to the stream channel if the culvert were to fail. Also consider diversion potential.
2. Presence or absence of other road crossings. Multiple roads under a variety of management or ownership may cross a single stream. Then, close communication with other road managers is important. If multiple culverts are migration barriers, a coordinated effort is required to identify and treat them in a logical sequence.
3. Presence of aquatic organisms attempting to migrate past a barrier. In Northern California, several crossings were ranked higher because of the annual presence of adult salmonids below total barriers. After treatments, the upstream habitat was immediately recolonized the following winter.
4. Remediation project cost. You should examine the range of treatment options and associated costs when determining the order in which to proceed and what should be implemented at specific sites. Where federally listed fish species are present, costs must also be weighed against the consequences of failing to comply with the ESA by not providing unimpeded passage.

Other limiting factors. Other limiting factors besides migration barriers often exist in a watershed and limit production of aquatic species. On a watershed or sub-basin scale, restoration decisions must be made after carefully reviewing potential limiting factors, the source of the effects, range of restoration options available, and what restoration activities are actually feasible.

APPENDIX B Fill-in-the-Blank Regional Screen, California model

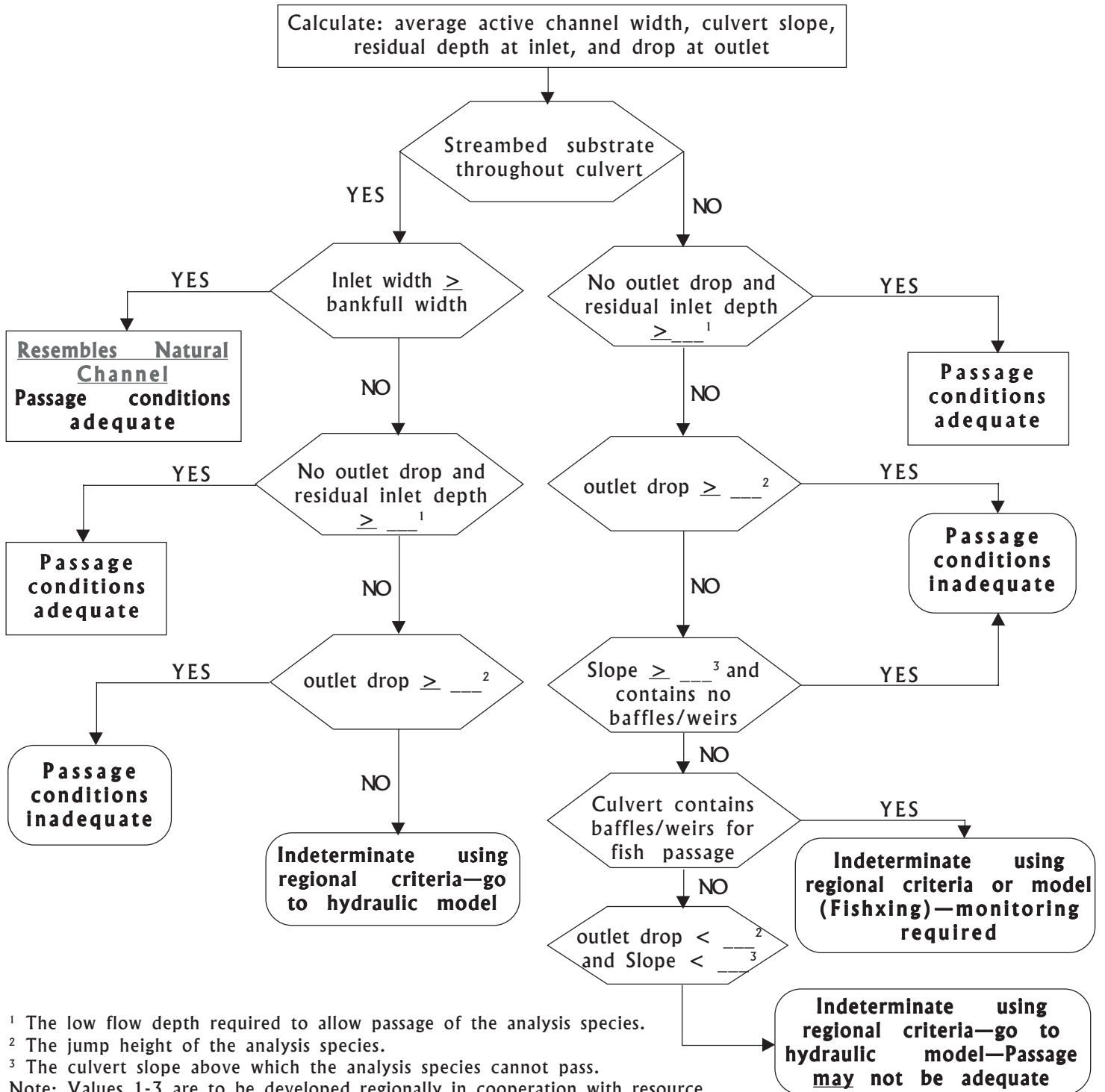

Passage inadequate: Crossing does not meet the criteria for the analysis species for which the screen is designed.
 Indeterminate barrier category: for analysis species using the screen.

APPENDIX C

Hydrology and flow requirements

Several states have defined flows at which fish passage should be provided. Except for Alaska and Idaho, these requirements apply only to hydraulic designs (not stream simulation).

STATE AND AGENCY GUIDELINES FOR FISH PASSAGE FLOWS

Alaska	Washington	Oregon	NMFS SW Region	California Dept Fish & Game (draft salmonid guidelines)	NMFS NW Region (draft salmonid)	Idaho
High Flow Capacity (crossing must pass this flow, but fish passage is not required)						
Q_{50} or Q_{100}	Q_{100} with debris	Q_{100}	Q_{100} at headwater/depth = 1	Q_{100} at headwater/depth = 1.5		
High Fish Passage Flow						
"Q2d2": the discharge 24 hours before or after the 2-yr flood	10% exceedance flow during migration period: species-specific	10% exceedance flow during migration period: species-specific. Approximate by $Q_{10\%} = 0.18*(Q_2) + 36$ where $Q_2 > 44$ cfs. Where $Q_2 < 44$ cfs, use Q_2 .	for adult salmon & steelhead 1% annual exceedance flow or 50% Q_2 . For juveniles, 10% annual exceedance flow	standards vary from 1%-10% annual exceedance for various groups of fish	5% exceedance flow for period of upstream migration	< 2-day delay during period of migration
Low Fish Passage Flow						
None	2-yr, 7-day low flow	2-yr, 7-day low flow or 95% exceedance flow for migration period: species-specific	for adult salmon & steelhead, the greater of 3 cfs or 50% annual exceedance flow. For juveniles, the greater of 95% annual exceedance flow or 1 cfs	standards vary from 50%-95% annual exceedance for various groups of fish	95% exceedance flow during months of upstream migration	

Q_{100} means the peak flow equaled or exceeded on average once in 100 years. Determined based on annual peak flow data set.

10% exceedance flow during the migration period means the daily average flow that is equaled or exceeded 10% of the days in the period the selected fish species are moving. That period is usually established by the state fish and wildlife management agency. Based on period of record daily-flow data set for the migration period.

1% annual exceedance flow means the daily average flow that is equaled or exceeded 1% of the days of the year. Determined based on period of record daily mean flow data set for the entire year.

APPENDIX D Example Job Hazard Analysis from Umatilla NF

JHA provided courtesy of John Sanchez, Umatilla NF

The Occupational Safety and Health Administration has requirements related to working in confined spaces [Safety training and Education – 1926.21(b)(6)(i)]. These requirements can be found at their website: www.osha.gov/pls/oshaweb.

U.S. Department of Agriculture Forest Service JOB HAZARD ANALYSIS (JHA) References-FSH 6709.11 and -12 (Instructions on Reverse)	1. WORK PROJECT/ ACTIVITY FISH PASSAGE CULVERT ASSESSMENT JUNE/SEPT 2001	2. LOCATION UMATILLA NATIONAL FOREST	3. UNIT R6-14
	4. NAME OF ANALYST J.SANCHEZ	5. JOB TITLE FISH BIOLOGIST	6. DATE PREPARED 05/25/2001
7. TASKS/PROCEDURES	8. HAZARDS	9. ABATEMENT ACTIONS Engineering Controls * Substitution * Administrative Controls * PPE	
* Driving on main roads as well as 4wd and other secondary roads which are heavily used by public, working long days	*potential for heavy traffic/fast vehicles; uneven roads; atv and bike use by recreationists; being tired while driving/lack of concentration on tasks /mental and physical errors	*follow safe and defensive driving practices; take rest breaks as needed; change drivers as needed	
*working in roadway and crossing the road	*high traffic volume on main roads; sites close to bends in roadway decreasing visibility	*watch for traffic and check both directions before crossing; post a lookout if needed; use caution especially at sites close to bends in the road. Wear hard hats and safety vests to increase crew visibility to oncoming drivers	
*climbing up/down banks, over rock and loose fill in wading boots	*poor foot traction in wading boots; easy to slip and fall; kicking loose rocks down onto workers below	* look for safest way down bank; don't rush; use a pole to help balance; make sure others are not directly below you as you climb up or down the bank	
*walking in culverts and in streams in wading boots	*culverts and rocks are slippery when wet and covered with algae; uneven surfaces in culverts and streams; strong flow	*don't rush; wear wading boots with felt bottoms; use a wading staff for support; be confident of your footing before taking next step in fast moving water	

7. TASKS/PROCEDURES	8. HAZARDS	9. ABATEMENT ACTIONS Engineering Controls * Substitution * Administrative Controls * PPE	
*climbing over/under/around timber and walking over uneven terrain and over vegetation covered ground in wading boots	* logs are slick when wet; hard to see the ground; unstable snags may fall; debris piles may be unstable; twisted ankles; snagging waders on limbs and fences	* find safest and easiest route around logs; go around or under instead of over; step cautiously on piles of debris; identify unstable snags and stay clear; use rod to help find stable/unstable spots	
*working outside in weather (heat/rain/cold/snow/thunder and lightning)	*dehydration; hyper and hypothermia; threat of storms	*drink plenty of water; dress appropriately for weather; monitor weather reports; carry a radio and extra batteries; keep dry clothes in vehicle.	
*working outside-encounters with snakes, bees, wasps, biting flies etc	*allergic reactions such as anaphylactic shock/ rash/swelling etc	*identify all crew member's allergies and inform all crew of potential health problems; always carry a first aid kit equipped with antihistamines/epi pin/benadryl as necessary in vehicle and in packs; discuss first aid techniques and training for all crew members as needed	
*conduct tailgate safety meetings as needed			
*use proper department check in / check out procedures	*		
*driving an all-terrain vehicle on forest roads		*follow safe operating procedures for atv; wear all appropriate safety gear (helmet, gloves, boots, long pants and long sleeved shirt); maintain safe and proper speed; scan ahead for hazards; keep all items strapped down tightly to avoid unexpected shifting of weight; carry a radio and 1 st aid kit in case of emergency	
10. LINE OFFICER SIGNATURE	11. TITLE	12. DATE	

Previous edition is obsolete (over)

APPENDIX E

Explanations and Instructions for Passage Through Road/Stream Crossings Inventory Form

These instructions accompany the Passage Through Crossings Assessment forms. The inventory collects information required to assess passage of fish and other animals through crossing structures on both roads and trails. The procedure does not handle bridges because most often these structures do not obstruct aquatic organisms. The data sheet can be modified if need be for field convenience. However, it is critical to preserve the definitions of the variables and the methods of measurement prescribed in this document. New database structures are being modeled now for storage of this data in Forest Service Infrastructure database (INFRA) and Natural Resources information system (NRIS).

Once the field data have been collected, a passage assessment is made in the field. First, determine whether the crossing resembles the adjacent natural channel. If it does, we assume it passes most organisms. The criteria for making this determination are listed under “Field Passage Evaluation” in these instructions. Second, if the crossing does not resemble the stream channel, then use the regionally developed species, lifestage, or species group-specific criteria to determine whether the structure’s passage conditions are adequate, inadequate or are indeterminate.

If you cannot determine whether the crossing is a barrier, and the analysis species is a fish for which swim performance information is available, then hydraulic analysis using FishXing can be conducted for many types of crossings. The FishXing software is available on the web at: <http://www.stream.fs.fed.us/fishxing>. See instructions and help files prior to running the program.

In addition to the information collected through this inventory the following inputs are also needed to run FishXing:

- Hydrologic criteria, including low passage flow and high passage flow.
- Fish information, including swimming capabilities and depth requirements.

Although the field assessment form is designed primarily for culverts, fords can also be inventoried. Instructions for taking measurements on fords are included. The survey measurements can support limited open channel flow analysis, but passage assessments on fords are usually a matter of directly observing animal passage. In these cases, more than a single visit may be needed to adequately assess their passage. Other complex installations difficult to model hydraulically, such as baffled culverts, may also require multiple visits.

Line-by-Line Instructions

Data elements in bold are required for Forest Service Infrastructure database (INFRA)/ Natural Resource Information System (NRIS) or are needed to evaluate passage at the crossing. Other data are useful for prioritizing culvert restoration, developing pre-project budget cost estimates, or to field check flow estimates used in FishXing analyses.

The last page of the form (p 69h) is not intended for field use. Its purpose is to document biological and watershed context information about the site that is critical to complete the permanent file, and for replacement project prioritization. Usually this form will be filled out in the office, before or after the survey.

A supplemental form is attached for sites where there are more than one pipe or box. In most cases, where there are several pipes in close proximity, only part of this form will be needed. However the complete survey pages are included for cases where side channel culverts are being evaluated separately for passage conditions.

Site

Some of this information can be collected in the office before beginning the field portion of the assessment.

Each crossing location should be clearly marked on the best available map, preferably an 8.5 by 11, 1:1 scale photocopy of a USGS 7.5-min. topographic quadrangle. Each map sheet should be labeled with the crossing identification number to help eliminate confusion both during the inventory and when crossing data are linked to GIS coverages.

Crossing site identification number box

If the culvert installation is already entered in INFRA, use the control number of the culvert installation as the crossing site ID number. Otherwise, this can be any number that uniquely identifies each crossing. It should be entered on each a page of the field form, and it should be used on photograph and map labels.

Where there is only one pipe at a crossing site, the single pipe will be identified as “Structure 1 of 1” and the structure milepost is the site milepost. For crossings with more than one pipe or opening, the crossing ID number identifies the site as a whole, and the individual pipes are numbered “structure 1 of __, structure 2 of __, etc. starting with the pipe closest to the beginning of the road (milepost 0). The principal structure—generally the lowest elevation since that will carry the lowest flows—is described on the main data sheet “Passage through Crossings Assessment.” Supplemental data sheets with the same crossing ID number are used to describe pipes other than the principal structure. Each additional pipe is described on a separate supplemental form, and its milepost is entered as **structure milepost** on that form. (See further explanation under Route number and INFRA Milepost.)

Multiple structures at one site

If a site has two or more structures (pipe or box) of the **same** size, materials, elevation, and orientation, measurements are needed only on whichever structure is identified as the principal one. This will be the pipe that conveys most flow. Note the number of other identical openings and their mileposts in the multiple structures box (see Figure E-1). Use the sketch to describe the accompanying culverts; also take photos. Each pipe will be entered in INFRA separately.

If a site has two or more structures (not including overflow pipes) that are **not** the same (i.e., they have different dimensions, elevations, shapes, etc), complete a supplemental form for each additional structure. Complete the main form for the principal structure, and in the **multiple structures** box indicate that one or more supplemental forms were filled out for this site (see Figure E-1).

Many sites have overflow culverts to convey high flows that exceed the capacity of the principal structure. As shown on Fig. E-1, some are simply above the main culvert. If one of your objectives is to determine site peak flow capacity, then all the “crossing structure” as well as slope data (pages 1 and 2) are needed for this kind of pipe. Since all pipes are entered separately into INFRA, you should complete the supplemental data sheets for them unless they are already in the database. If you do not need the individual pipe data, simply note the number and mileposts of the overflow culverts in the **multiple structures** box (___ number of overflow pipe(s), no supplemental forms”) and include them in sketches and photos.

Sometimes determining what the “site” is will be difficult—where a very wide floodplain has relief culverts for flood flows under the road, for example. In deciding how to handle such crossings, consider how the site hydrology will be developed. Where pipes are on the floodplain of a single channel, consider lumping them into a single crossing site. Some floodplain pipes are on side channels that also require passage assessments. The supplemental field form includes pages (4-6) for channel data that would be needed to compare the side channel culvert to the natural side channel. The surveys for the main pipe and floodplain pipes should be tied together using the same control points. Be sure to describe the relationships in the comments section.

Note that pages 4-6 in the multiple structures supplemental form will not be needed except for unusual situations, such as side channel culverts where passage is required. Pages 1-3 should be filled out for all structures.

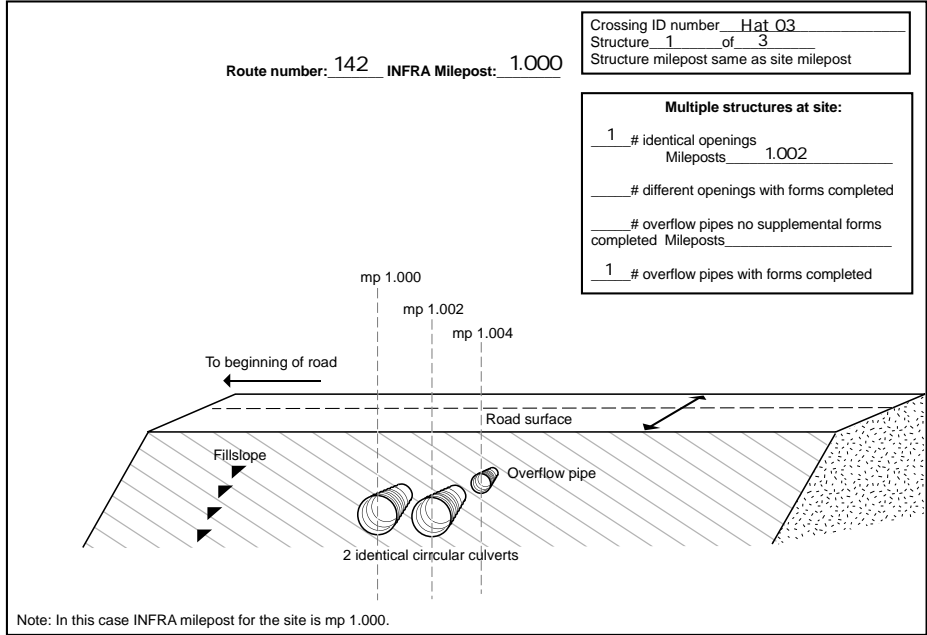

Figure E-1. Multiple structures at one site.

Route number and (INFRA) milepost (office or field determination)	<p>Record the road or trail number, and the site INFRA milepost, if known. If the installation is not entered in INFRA yet, measure the mileage from the beginning of the route to the center of the first (or only) pipe in the installation (see Road User Board Meeting Notes, Redding CA, 4-2002). The milepost of the first pipe in a multiple-structure installation is always the site milepost.</p> <p>The supplemental forms (for structure 2 of X, etc.) do not include site milepost, since the site is identified by the crossing ID. Other structure mileposts are entered on the supplemental sheets in the crossing ID box. Mileposts for different structures at the same site should be recorded in 1/1000ths of a mile (for example, culvert 1 = MP 1.000, culvert 2 = MP 1.001).</p> <p>Where available, use a distance measuring instrument (DMI) attached to the vehicle for accuracy. For more information see http://www.nu-metrics.com. Click on NIT-ESTAR on left column. Approximate cost is around \$150-\$250 for unit, installation kit, and installation.</p>
Milepost from junction of road number (field determination)	<p>Driving from the beginning of the route to the crossing site is the most direct and accurate way to get the INFRA milepost. Be aware that if you access the site by another—perhaps shorter—route it may be difficult to accurately locate the site later. If you do take a different road to the site, record the mileage from a clearly identifiable junction on the road you actually drove (for example, 1.5 miles from intersection of road 123 with road 145). Be sure to take a GPS reading at the crossing.</p>
Forest and district	<p>For non-Forest Service land, substitute appropriate administrative units.</p>
Watershed (office determination)	<p>Enter the hydrologic unit code (HUC) number of the watershed or sub-watershed. Use the 6th-field HUC where possible.</p>
Stream name (office determination)	<p>Get the stream name from USGS 7.5-minute quad or other local sources. If a crossing is on an unnamed stream that is a tributary of a larger sub-basin in a major basin, include all named sub-basins. For example: unnamed, tributary to Davis Creek, tributary to Outlet Creek, tributary to South Fork Eel River, Eel River watershed.</p>
USGS topographic quad name, ownership, and legal description	<p>Input the USGS quadrangle name, the land ownership or jurisdiction, the legal description (township, range, section), and principal meridian.</p>
Global positioning system location	<p>Record the X and Y coordinates from the GPS unit for permanent site identification, along with the datum (eg., NAD27). If you use something other than latitude and longitude, note the coordinate system and zone.</p>
Surveyors	<p>Record the surveyors names.</p>
Field date	<p>Enter the date the field data are collected.</p>

Crossing structure shape

Choose appropriate type of culvert or ford, and measure dimensions. Depicted below are the barrel cross-sections of common culvert types that can be modeled in FishXing.

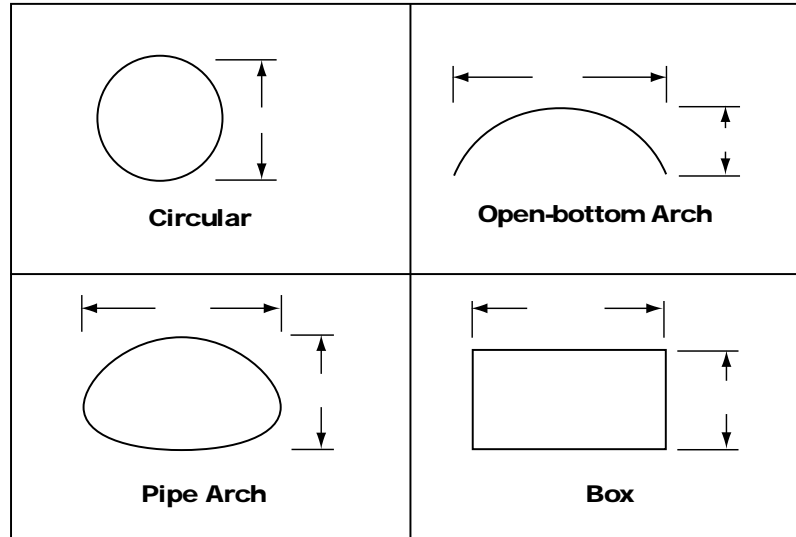

Figure E-2. Common culvert shapes.

Log culverts, “Humboldt” crossings (porous structure made of stacked logs), irrigation diversion structures, and other less common crossings are described under “other”. For analysis in FishXing, select the shape from the four above that most closely resembles the observed pipe, using as criteria similar cross-section area and wetted perimeter at passage flows. Other culvert shapes should be described in enough detail to permit determination of pipe capacity from information provided by the manufacturer or from other sources.

Ford Types

The two types of low-water fords are unvented (Figure E-3) and vented (Figure E-4). At unvented fords, traffic drives through the stream until increasing flows cause the water to become too deep to traverse. Unvented concrete fords are often barriers to fish passage at low flows because of the shallow flow depth. Some of these have slots of various sizes, with or without grated coverings that may allow fish and amphibian passage.

A vented ford includes a low-flow conveyance structure such as a culvert, so that traffic does not travel through the water at low flows. Only at moderate or high flows is the vented ford submerged. The many designs of vented fords include:

- A single pipe or box;
- Multiple round or box culverts that are essentially identical; and
- Multiple round or box culverts with one pipe designed to capture all of the low flow.

In vented fords the vent is described as a culvert for the inventory, and the ford dimensions in Figure E-4 (F1, F2, and sag) are also measured. Check both structure shapes on the form. True fords, where vehicles cross at streambed elevation, are “fords”, whether or not they have a slot for aquatic organism passage.

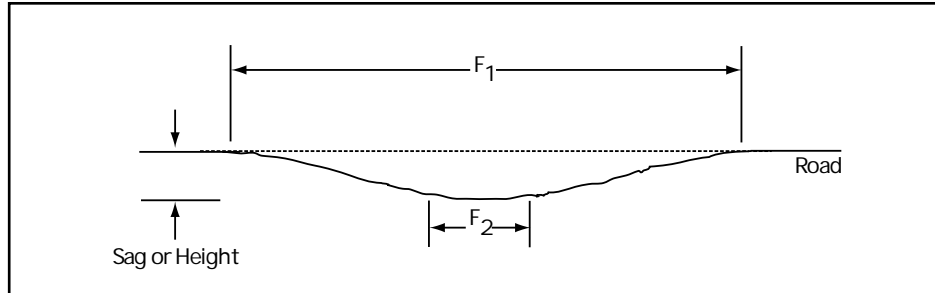

Figure E-3. Low water ford (unvented)

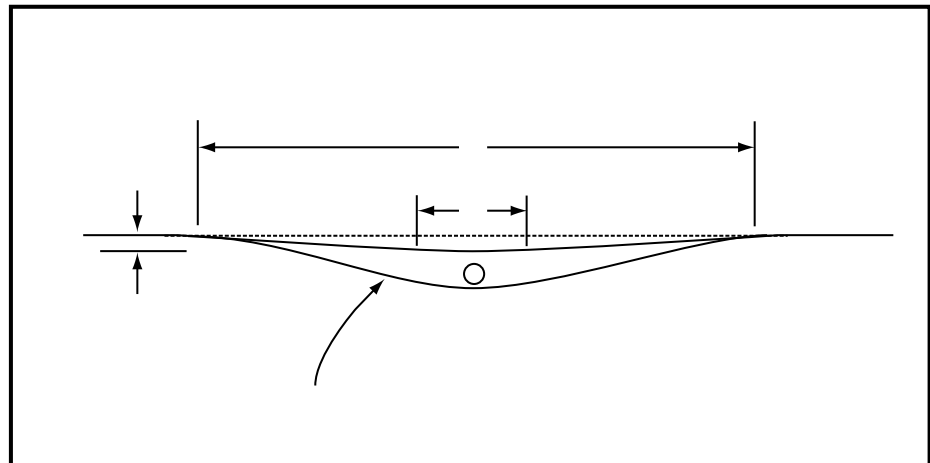

Figure E-4. Low water ford (vented)

Culvert dimensions

Record the maximum width (span or diameter measured horizontally) and the height (rise or diameter measured vertically) of the culvert, measured from the inside of the corrugations.

- Circular culverts and pipe arches. Measure both height and width. Pipes are often distorted during and after installation.
- Open-bottom arches. For open-bottom arches, measure the width of the pipe from metal to metal, not from foundation to foundation, unless the streambed is scoured to below the top of the foundation. Then, also measure flow width between foundations and the depth of scour below the top of the foundation at top and bottom of the pipe (in FishXing this configuration may be modeled as a flat-floored rectangular box). Measure the height of the pipe from the streambed to the top of the culvert.
- Embedded pipes. If possible, dig or probe to find the depth of substrate at the inlet and add that to the height measured from the bed to the pipe top. If that is not feasible, culvert height can be estimated from width for standard pipe shapes (see AISI 1994 or FishXing). Many structures are manufactured that do not conform to “standard” dimensions, so it is advisable to measure substrate depth directly.

Ford Dimensions – optional data

Aside from the standard culvert or box data on the vents in vented fords, ford dimensions only need to be measured if average flow velocities and/or peak flow capacity estimates are desired. FishXing cannot be used for fords during overflow conditions. Open-channel flow equations (e.g., Manning s) or weir equations can be used to make velocity and depth estimates where the assumptions specific to each equation are met.

Three measurements are needed to describe the shape of any ford.

- F1 is the width (horizontal distance measured parallel to the road) of the top of the ford; that is, between the points on the road at which the roadway transitions out of its vertical curve (see Fig. E-3). This measurement helps determine the structure s peak flow capacity.
- F2 is the width (horizontal distance measured parallel to the road) of the bottom of the ford. Low-flow depths across the ford will be determined by this width.
- Sag or Height – The vertical difference in elevation between the bottom of the ford and the elevation of the roadway if it were projected across the ford.

Some unvented fords have slots to accommodate fish or amphibian passage during low flows. The dimensions of the slot should be noted and its slope and any perch should be measured during the survey (see **The Survey**, below).

Rust line

If the culvert is made of steel it will have a rust line. Measure the height of the rust line above the culvert bottom away from noticeable elevation changes near the inlet or at obstructions. The rust line indicates a persistent high flow. The actual exceedance value or recurrence interval of this flow is expected to vary across the country depending on the local streamflow regime.

Structural material

If the culvert material does not fall into one of the following categories, give a brief description characterizing its roughness.

- Corrugated metal pipes (CMP) are constructed from single sheets of corrugated metal. Spiral culverts have helical corrugations, reducing the culvert roughness. Annular culverts have concentric corrugations.
 - * Steel = corrugated steel, may show rust line.
 - * Aluminum = corrugated aluminum, no rust line.
- Structural plate pipes are constructed of multiple plates of corrugated galvanized steel or aluminum bolted together. They always have annular corrugations.
- Plastic may or may not have corrugations.
- Concrete is used in many box and some circular and arch culverts.
- Wood and logs are used to make log stringers, log box culverts, and circular culverts.

Ford surfaces also vary, ranging from natural stream bottom with no improvements to paved road surfacing. The surface designs of most concern for animal passage are those that are smooth; these surfaces tend to reduce water depths at low flows and increase velocities at high flows. In addition, high water velocities across smooth ford

surfaces cause scour of the natural streambed downstream, usually creating a perch at the outlet of the ford. In ford surface materials under “other” write in natural streambed, asphalt, geotextile/gravel, concrete, pit run, or other rock.

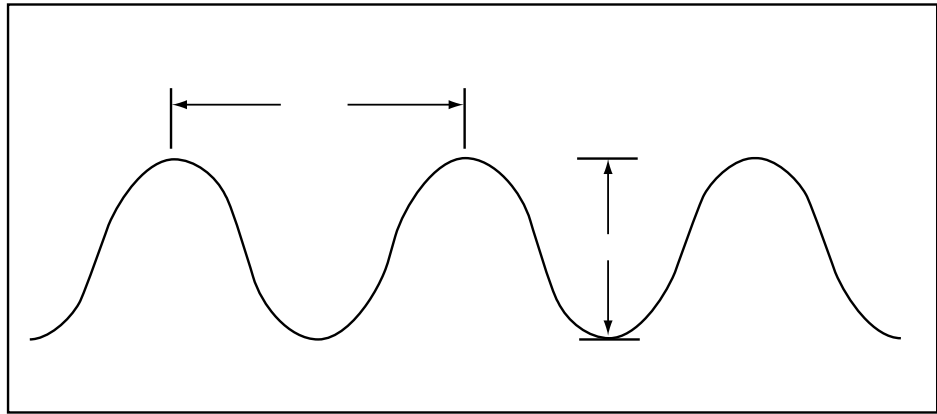

Figure E-5. *Measuring corrugations.*

Corrugations

Measure the width and depth of the corrugations in inches (see Figure E-5). Most CMP under 60 inches in diameter have 2 2/3-inch x 1/2-inch corrugations. CMP greater than or equal to 60 inches in diameter typically have 3-inch x 1-inch corrugations. Structural plate pipes (SPP) and structural plate pipe arches (SPPA) often have 6-inch x 2-inch corrugations. The size of the corrugations determines the culvert roughness, which is used in FishXing. Corrugations are measured from crest to crest (width) and valley to crest (depth). Measure them in areas without deformation

Inlet type

Mark all inlet descriptions that fit (see Figure E-6). The culvert inlet type determines the headloss coefficient at the inlet of the pipe. This coefficient is a measure of the energy loss as water enters the pipe, and is required for the hydraulic analysis performed in FishXing.

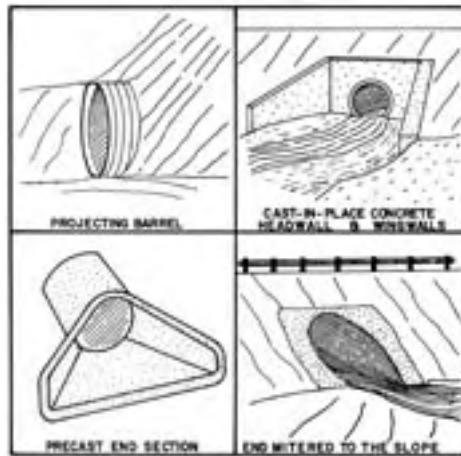
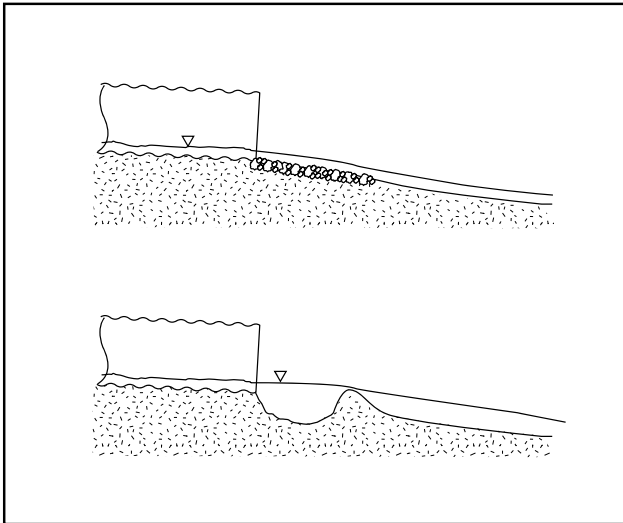
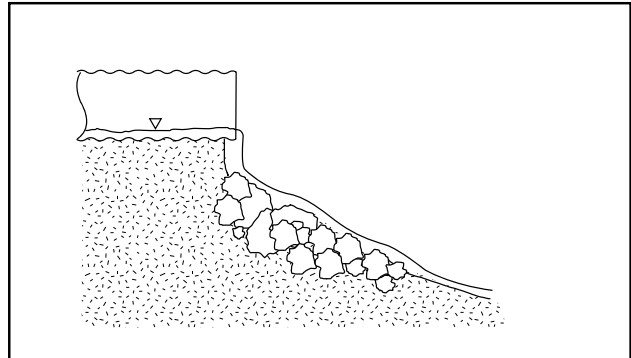

Figure E-6. (from Normann et al 2001). Inlet type examples (clockwise from top left): projecting, headwall and wingwall, mitered and metal or cement end section. Wing-wall measurement is illustrated here.

Outlet Types



E8a—At streambed elevation



E8d—Freefall onto riprap

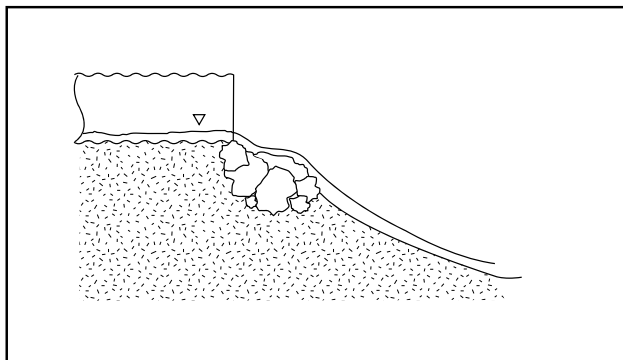

E8b—Cascade over riprap

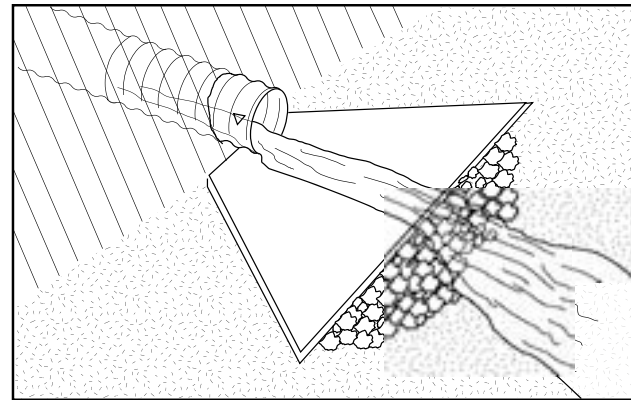

E8e—Onto outlet apron

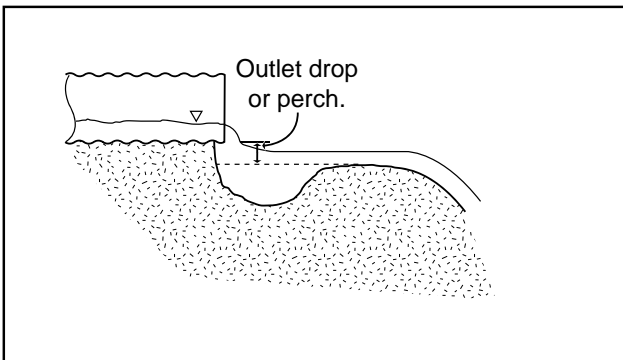

E8c—Freefall into pool

Figure E-8. Outlet types.

Baffles and weirs

If the culvert contains baffles, weirs, boulders embedded in concrete, or other fabricated structures inside the culvert, give a brief description. Because baffle designs are often not standardized, a sketch with detailed dimensions is needed. Describe the structures' location in the pipe, materials, spacing, height, and configuration. Also describe any notch shapes, dimensions, and arrangement.

Pipe condition

Identify problems that could cause the culvert to plug or fail and affect resources. Check any of the observed conditions or note any not listed.

- Breaks in slope inside of culvert: Make sure they are actual breaks and not just debris build up. If removing the debris would eliminate the break, it is not a slope break. Estimate horizontal distance to the break from the outlet and estimate the vertical difference.
- Debris plugging inlet (estimate the percentage of inlet that is blocked)
- Fill eroding
- Bent inlet
- Debris plugging inlet
- Bottom worn through
- Debris in culvert
- Water flowing under culvert
- Other (such as, streambed scouring between open-bottom arch foundations)

Many of these elements can also be used to describe unvented fords. Other observations pertaining to fords might be: surface cracked (for concrete or asphalt), water running around edge of ford, ford surface rutted, toe of fill undermined, and so on.

Briefly describe the condition of functioning or needed BMPs such as fillslope vegetation or other erosion controls, downstream grade controls, etc. Show problems in a sketch and photographs.

Diversion potential— (optional data for prioritization)

This is one of the factors influencing the magnitude damage to the stream and road if the crossing should fail. Most decision makers will consider this as they decide which crossings should be replaced first. Streams can be diverted at crossings if the road has “a continuous climbing grade across the stream crossing or where the road slopes downward away from a stream crossing in at least one direction” (Flanagan and others 1998). For a full description of diversion potential assessment please read Flanagan and others (1998) available on the web at: <http://www.stream.fs.fed.us/waterroad/w-r-pdf/diversionpntl.pdf>.

Fill volume estimate— (optional data for prioritization and cost estimates)

These data are optional in INFRA. These measurements are intended to define the prism of soil that would:

1. be removed to reconstruct the crossing (a major component of replacement cost) or
2. be eroded during crossing failure causing potential harm to downstream habitat.

Substrate particle sizes

Rank (1-highest) the first three substrate sizes that occupy the greatest area of the streambed. Take the substrate sizes in three locations: 1) in the structure, 2) at the tail water control, and 3) in the channel outside the influence of the crossing. Usually the last observation is taken at the same location as the channel width and slope measurements (and reference cross section, if included). Substrate sizes from locations 1) and 2) are needed to calculate Mannings “n” roughness coefficients for FishXing. Substrate size around the reference cross-section determines the roughness value used to calculate flows through that cross-section. All three locations are used to evaluate if the crossing resembles the adjacent natural stream channel and for pre-design replacement cost-estimates.

Use the following definitions of substrate particle sizes:

- Bedrock = large masses of solid rock;
- Boulder = > 256 mm (>10 inches);
- Cobbles = 64 to 256 mm (2.5 to 10 inches);
- Gravel = 2 to 64 mm (0.08 to 2.5 inches);
- Sand = .06 mm to 2 mm (< 0.08 inches);
- Silt and clay = difficult to differentiate individual grains;
- Organics = muck, organic ooze; and
- Aquatic macrophytes (rooted aquatic vegetation).

Bankfull channel widths

Measure the width of the channel at the bankfull level. Five measurements (including the cross-section, if measured) should be taken across straight stretches of the channel and then averaged. Space the five measurements out over the reach used to measure channel gradient (8-10 channel widths in length), which should be well above any influence the stream crossing may have on channel width or slope. Undersized culverts can influence the channel width for several hundred feet upstream as a result of ponding storm runoff and causing bedload deposition. Because crossings are often near natural slope breaks, look for significant channel changes near the crossing. If upstream and downstream reaches are very different, slope and width should be measured on both reaches.

In many places, bankfull discharge is a high flow occurring every one to two years on average. Bankfull elevation can be tricky to identify in the field, and field personnel should be thoroughly trained by specialists familiar with the hydrologic regime, stream morphology, and riparian vegetation of the area. Information on how to recognize bankfull elevation can be found in “Applied River Morphology” by Dave Rosgen, “Stream Channel Reference Sites” by C.C. Harrelson and others, and two videos published by the Stream Team: “A guide to Field Identification of bankfull stage in the western United States”, and “Identifying bankfull stage in forested streams in the eastern United States” (www.stream.fs.fed.us).

Survey calculations

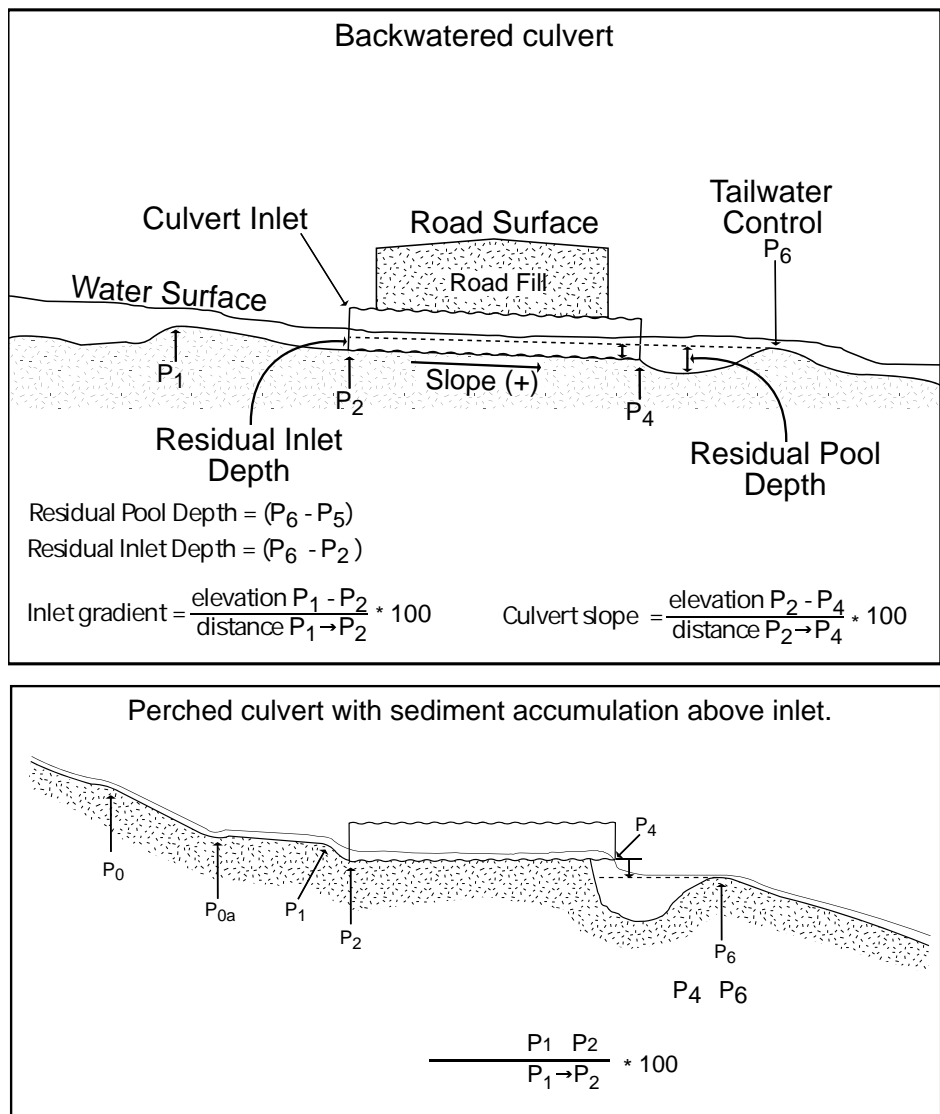

Figure E-15. Survey calculations.

Calculate the following, using the surveyed elevations and distances (See Figure E-15):

- **Culvert slope**—Culvert slope in percent is the inlet outvert elevation minus the inlet invert elevation divided by the horizontal culvert length, multiplied by 100. In general, culvert slopes and lengths are such that, for assessment purposes, slope distance can be used in this calculation. Use streambed elevations for embedded culverts.
- **Outlet drop**—The outlet drop is the jump at the outlet of the structure that a fish must negotiate to enter the structure. At extreme low flows the outlet drop is controlled by the substrate elevation at the tailwater of the outlet pool (Figure E-15). The total outlet drop is the elevation difference between the outlet invert and the downstream tailwater control. Tailwater elevations will be higher than the lowest point in the tailwater control, as long as flow continues across the control; the outlet drop measurement represents the highest jump possible (the jump that would be needed at zero flow). Where hydrologic data indicate that

flows never approach zero, as in spring-fed streams, this calculation will give an unrealistic overestimate of perch height. In this situation the analyst should make allowance for low-flow water depth.

- **Channel gradient**—The difference in the elevation of the water surface measured at two points along the natural channel divided by the length of channel between those two points (use up and downstream ends of channel segments, measured under “channel slope”). The measured length should follow the stream’s course and not the shortest distance between two points. Calculate both upstream and downstream gradients if they are different.
- **Inlet gradient**—Calculate the gradient immediately upstream of the inlet as an indicator of adverse inlet conditions. Passage may be impaired if channel gradient directly above the structure is steeper than the average channel gradient.
- **Inlet width to bankfull channel width ratio**—For a crossing structure to meet the criteria for stream simulation, this ratio must be 1 or greater. Structures that do not constrict the channel at most flows are generally more successful at passing fish and other biota.
- **Residual inlet depth ($P_6 - P_2$)**—The residual inlet depth is the depth of water at the inlet of the structure under no or very low flow. When the outlet tailwater control elevation is higher than the invert of the inlet, the residual inlet depth will be a positive number and the structure will be backwatered at all flows. A positive residual inlet depth is generally conducive to passage of most species and life stages. Write 0 if the tailwater control is lower than the inlet invert.
- **Residual pool depth ($P_6 - P_5$)**—The residual pool depth is the depth of water in the outlet pool under no or very low flow. Some species, notably salmonids, may be able to negotiate an outlet drop providing there is a jump pool of sufficient depth is present.
- **Substrate ratio**—The substrate ratio is the ratio of the depth of the substrate to the height of an embedded structure. Substrate ratio is important to the function of structures that simulate the stream. The substrate must be deep enough that the channel inside the structure is able to adjust vertically over the range of design flows. Generally 20% depth of embedment is considered a minimum.

Unvented fords that have some accommodation for fish passage may be surveyed if, for example, baseline measurements are desired for later comparison. Channel and ford widths and slopes, as well as any grade breaks, should be the focus of the survey.

Field passage evaluation

Use the following assessment criteria to determine the barrier category of the crossing structure.

Check resembles natural channel if:

- The streambed substrate is continuous through the structure;
- The inlet width is greater than the channel width (inlet width to channel bankfull width ratio > 1.0);
- No outlet drop exists, and
- No other obvious factors are affecting passage (such as, trash racks or drop inlets) are present.

If the structure does not meet these criteria, then use the analysis species regional coarse filter criteria to categorize the crossing. The categories include: passage adequate, passage inadequate, or when passage is uncertain, passage indeterminate. List the species, lifestage, or species group that the regional criteria are based on. If your evaluation differs from the coarse filter assessment criteria, be sure to explain why.

Comments

Use this section to:

- Clarify items that may not be clear in the data, the site sketch, or the photographs;
- Describe any data-gathering problems;
- Record qualitative notes describing stream habitat immediately upstream and downstream of the crossing;
- Report any fish present at the site; include number, size, and species, if known (remember that rigorous inventory methods are needed to document species absence);
- Note any possible upstream or downstream barriers;
- Bank vegetation near the culvert; and
- Describe any substrate structure inside the pipe (such as, step-pools, meandering, presence of a low flow channel, or substrate exposed at low flows that might be usable by crawling species).

Photographs

- Photograph all culvert locations. At a minimum, photographs of the inlet, outlet, and tailwater control of each culvert are required. We also recommend that a photo be taken from the inlet looking upstream to show streambed conditions and possible obstacles for exiting fish. For low-water crossings, take photos from both upstream and downstream. Where multiple structures are present, photograph all of them to show their locations and arrangements. Also show the driving surface of fords. For information on using spatially referenced photographic techniques to document the survey, see <http://csmres.jmu.edu/forest-service>.
- Record the global positioning system location of the photo points if desired.
- On the site sketch, mark your photo points so future photographs can be taken from the same places.
- Photograph any unique features about a site, such as steep drops at inlets; perched outlets; breaks-in-slope; poor or damaged condition; outlet pool conditions; and habitat above and below the site.

Site sketch

Sketch each stream crossing and the surrounding site, including relevant features of the adjacent stream reaches. The sketch and notes are as important as the data collected. Include the following features in site sketches:

- North arrow;
- Direction of stream flow, road number/name, and stream name;
- Alignment of stream channel and culvert inlet;
- Locations of photo points;
- Wingwalls and inlet /outlet aprons and their dimensions;

- Locations and designations of multiple structures at one site;
- Baffle configuration, dimensions, and number of sets;
- Weirs and other instream structures;
- Upstream or downstream debris jams;
- Trash racks, screens, standpipes, drop inlets, or any other structure associated with the crossing that may affect passage;
- Damage or obstacle inside structure;
- Location and quantity of riprap for bank armoring or jump pool formation.

How the culvert is aligned with the upstream channel can have very important effects on aquatic species passage and should be well documented on the sketch. A severe angle of approach to the inlet (see Figure E-16) can cause floating pieces of wood to plug the culvert, and can induce sediment deposition, bank erosion and inlet scour in some open-bottom structures. If the inventory will be used for preliminary design, the sketch should also show stream meanders and side channels in the vicinity of the crossing.

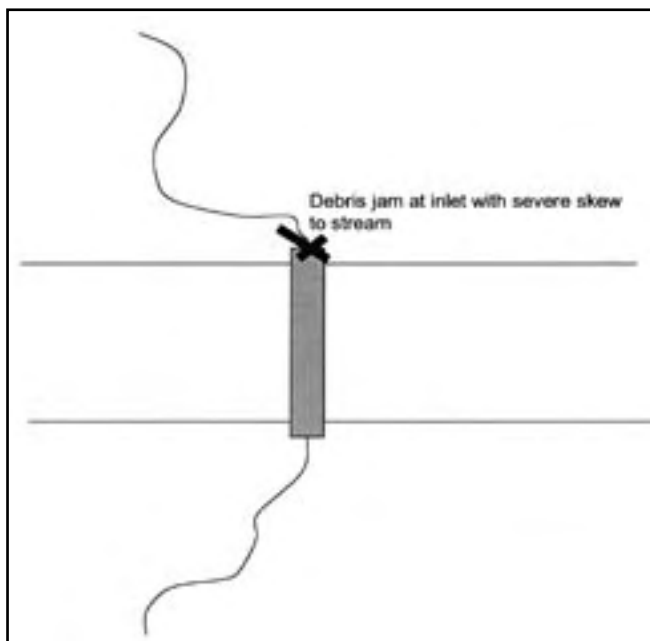

Figure E-16. The site sketch should show stream location, with special attention to culvert inlet and outlet. It should include any erosion and deposition features.

Reference cross-section (optional)

Low and high passage flows needed in FishXing are often derived from USGS regression equations with large standard errors of estimation. A reference cross-section can be surveyed to help determine if the results are reasonable. To get an independent estimate of bankfull flow, average cross section velocity and discharge are calculated from the hydraulic slope, cross section geometry and roughness. Several methods are described in detail in the WinXSPRO User s Manual (USDA-FS 1998).

The cross-section should be located outside the area of influence of the culvert—usually upstream—and should be in a relatively uniform, straight channel section. Use the same procedure described for the tailwater cross-section.

Channel slope outside of structure's influence (Optional)

Slope is needed for the reference cross-section flow calculations. Some practitioners also measure it both up and downstream to establish the crossing's context within the longitudinal profile of the natural channel. Often roads are built on slope breaks and the up and downstream gradients are quite different. Determine the natural channel gradient by measuring water surface slope. Take several elevations at the water's edge along a representative segment of stream that is outside the crossing's influence. Segments should be at least 8-10 channel widths long and the endpoints should be taken at similar streambed locations, preferably at riffles or runs.

Usually you will need to move away from the crossing to get representative channel slope measurements. If moving the level is awkward because of dense vegetation, you can use a hand level mounted on a rod of known height. With a hand level, several points on the water margin elevations are likely to be needed because the rod cannot be read at long distances. Record rod readings and distances between each measurement. As the two crewmembers move progressively up or down the channel, the next rod reading must be taken from the exact spot the rod was held for the previous reading. Note that when this method is used, the channel slope measurement may not be tied into the survey benchmark.

Biological and watershed information

This sheet documents critical information needed to complete the permanent record of the site survey, and to assist in making prioritization decisions. **Field crews do not need this page in the field.**

Analysis species

Because passage requirements are specific to species, lifestage (size), or species groups¹, so are barrier determinations. The inventory procedure described here results in enough data to assess passage for many fish species, life stages, or species groups in most situations. Your list of species may be broader than fish, however. Therefore, we recommend identifying specific species, life stages, or species groups in the planning stages, to allow for the eventuality that additional data might need to be collected for these non-fish species.

List the species, life stages, or species groups for that will be used in to assess passage at the crossing. In the comment section, note the reason for choosing each species.

Length of upstream and downstream habitat (prioritization data)

Record the length of upstream and downstream habitat that will become accessible by restoring passage at the site. To make this a more complete prioritization tool, also note habitat quality.

Upstream and downstream crossings and other potential barriers (prioritization data)

Record upstream and downstream crossings separately. If there are upstream crossings in the watershed, record the number. Record the distance in feet to the nearest upstream crossing (1st crossing) and check yes or no to indicate if it is a known barrier for the selected species. Do the same for the next nearest upstream crossing (2nd crossing). Follow this same procedure for downstream crossings and for other barriers and record the results in the spaces provided.

The presence of other barriers in the drainage network is important information for deciding the amount of benefit that will be gained by restoring passage at the crossing.

¹ *Species group: A group of species with similar morphology, swimming capability and behavior. The capability is used to determine the values in the regionally defined flowchart that classifies the passage status of a crossing.*

**Crossing is a barrier
to exotic species**

Indicate whether the barrier is to be left in place to limit the upstream expansion of exotic species. This information will be input to INFRA. (Footnotes)

Passage Through Crossings Assessment

SITE

Forest _____ District _____

Route number: _____ INFRA milepost: _____

Milepost: _____ from junction of road no. _____

Watershed 6th HUC or name: _____ Stream name: _____

7.5-minute quad name: _____ Land ownership: _____ NF _____ Other: _____

Legal description: T. __ S / N, R. __ E / W, Sec. __, __ ¼ of __ ¼ Principal meridian _____

X/Y Coordinates _____ Coordinate system _____ Datum _____

Surveyor names: _____ Field date: __ / __ / __

Crossing ID number _____
Structure _____ **of** _____
Structure milepost _____

CROSSING STRUCTURE

Shape

- Circular
- Box
- Open-bottom arch
- Pipe-arch
- Ford
- Vented ford
- Bridge
- Other: _____

Dimensions (inches)

width: _____ height: _____

Rust line: _____ (feet)

Ford data: sag _____
 F₁ _____
 F₂ _____

Multiple structures at site:

____ # other openings identical to main structure
 Mileposts _____

____ # different openings with forms completed

____ # overflow pipes----no forms completed
 Mileposts _____

____ # overflow pipes with forms completed

Structure shape comments _____

Structure material

- Spiral CMP
 - Annular CMP
 - Structural plate
 - Concrete
 - PVC
 - Wood or log
 - Other: _____
- Steel Aluminum

Corrugations

- 2 2/3 x 1/2 inch
- 3 x 1 inch
- 5 x 1 inch
- 6 x 2 inch (SSP only)
- None
- Paved or smooth invert
- Other: _____

Skew from road

_____ degrees

Inlet type

- Projecting
- Mitered
- Wingwall 10-30°
- Wingwall 30-70°
- Headwall
- Apron
- Trashrack
- Other: _____

Describe: _____

Outlet configuration

- at stream grade
- cascade over riprap
- freefall into pool
- freefall onto riprap
- outlet apron
- Other: _____

Describe: _____

Fill Volume

L_u (upstream fill slope length): _____

L_d (downstream fill slope length): _____

S_u (slope of upstream fill): _____ %

S_d (slope of downstream fill): _____ %

W_r (Road Width): _____

W_f (length of road on fill): _____

W_c (length of fill base): _____

Baffles, weirs or other internal structures: Yes No Material: _____

Describe (see sketch): _____

Pipe condition: Breaks inside culvert (Location _____)

- Fill eroding Debris plugging inlet (% blockage _____) Bent inlet Bottom worn through
- Poor alignment with stream Debris in culvert (rock or wood) Bottom rusted through Water flowing under culvert
- Other _____ Describe overall condition _____

Diversion Potential: Yes No Comments: _____

SITE SKETCH

Include:

- North Arrow
- Direction of stream flow
- Culvert/channel alignment
- Lay of tape if needed
- Photo point locations and numbers
- Wingwalls and inlet / outlet aprons
- Multiple structures
- Baffle configurations
- Weirs and other instream structures
- Debris jams inside, upstream and downstream near site, depositional bars
- Trash racks, screens, standpipes etc. that may affect passage
- Damage to or obstacle inside structure
- Location of Riprap for bank armoring or jump pool formation
- Tailwater cross-section location

Optional Channel Reference Data

Crossing ID Number _____ **Structure** ___ of ___

CHANNEL SLOPE---- measured outside of culvert influence
Upstream (include upstream channel cross section in reach)

Slope = cumulative elevation change/cumulative distance

Station	BS (+)	HI	FS (-)	Elevation	Cumulative

Upstream slope _____

Downstream

Station	BS (+)	HI	FS (-)	Elevation	Cumulative

Downstream slope _____

Note: Slope measurements should be taken at the water surface and at the same stream feature (such as, pool and pool, or riffle and riffle).

Reference cross-section

Describe location:

Station	BS (+)	HI	FS (-)	Elevation	Notes

<p>Reference cross section recommended points (minimum)</p> <table style="width: 100%; border: none;"> <tr> <td style="width: 33%;">Left bankfull</td> <td style="width: 33%;">Thalweg</td> <td style="width: 33%;">Right toe of bank</td> </tr> <tr> <td>Left edge of water</td> <td></td> <td>Right edge of water</td> </tr> <tr> <td>Left toe of bank</td> <td></td> <td>Right bankfull</td> </tr> </table>	Left bankfull	Thalweg	Right toe of bank	Left edge of water		Right edge of water	Left toe of bank		Right bankfull	<p>Measured Discharge _____ cfs</p> <p>Manning's n _____</p>
Left bankfull	Thalweg	Right toe of bank								
Left edge of water		Right edge of water								
Left toe of bank		Right bankfull								

Crossing ID number _____

Site Biological information – (Core data and prioritization data)

ANALYSIS SPECIES

Core data			Prioritization data	
Species	Life Stage	Comments	Upstream habitat blocked (mi)	Downstream habitat blocked (mi)
1.				
2.				
3.				
4.				
5.				
6.				
7.				
8.				
9.				
10.				

Habitat Quality Notes:

Watershed Information – Prioritization data

Exotic Species Crossing Barrier

<u>Upstream crossings:</u> No. of crossings _____ Distance to 1 st crossing (ft): _____ Barrier Y <input type="checkbox"/> N <input type="checkbox"/> Distance to 2 nd crossing (ft): _____ Barrier Y <input type="checkbox"/> N <input type="checkbox"/>	<u>Downstream crossings:</u> No. of crossings _____ Distance to 1 st crossing _____ mi Barrier Y <input type="checkbox"/> N <input type="checkbox"/> Distance to 2 nd crossing _____ mi Barrier Y <input type="checkbox"/> N <input type="checkbox"/>
<u>Other upstream barriers:</u> No. of barriers: _____ Distance to 1 st barrier: _____ mi Height _____ ft Distance to 2 nd barrier: _____ mi Height _____ ft	<u>Other downstream barriers:</u> No. of barriers _____ Distance to 1 st barrier: _____ mi Height _____ ft Distance to 2 nd barrier: _____ mi Height _____ ft

Is a barrier necessary at this site to meet management objectives, that is---passage barrier okay?

Yes No

Passage Through Crossings Assessment

Multiple Structures Supplemental Form

CROSSING STRUCTURE

Crossing ID number _____

Structure _____ **of** _____

Structure milepost _____

Shape

- Circular
- Box
- Open-bottom arch
- Pipe-arch
- Ford
- Vented ford
- Bridge
- Other: _____

Dimensions (inches)

width: _____ height: _____

Rust line: _____ (feet)

Ford data: sag _____
 F₁ _____
 F₂ _____

Structure shape comments _____

Structure material

- Spiral CMP
 - Annular CMP
 - Structural plate
 - Concrete
 - PVC
 - Wood or log
 - Other: _____
- Steel Aluminum

Corrugations

- 2 2/3 x 1/2 inch
- 3 x 1 inch
- 5 x 1 inch
- 6 x 2 inch (SSP only)
- None
- Paved or smooth invert
- Other: _____

Skew from road

_____ degrees

Inlet type

- Projecting
- Mitered
- Wingwall 10-30°
- Wingwall 30-70°
- Headwall
- Apron
- Trashrack
- Other: _____

Describe: _____

Outlet configuration

- at stream grade
- cascade over riprap
- freefall into pool
- freefall onto riprap
- outlet apron
- Other: _____

Describe: _____

Baffles, weirs or other internal structures: Yes No Material: _____

Describe (see sketch): _____

Pipe condition: Breaks inside culvert (Location _____)

- Fill eroding Debris plugging inlet (% blockage _____) Bent inlet Bottom worn through
- Poor alignment with stream Debris in culvert (rock or wood) Bottom rusted through Water flowing under culvert
- Other _____ Describe overall condition _____

Diversion Potential (prioritization data): Yes No Comments: _____

Crossing ID number _____ Structure ____ of ____

STREAMBED SUBSTRATE RETENTION IN STRUCTURE

- No substrate in structure
- Discontinuous layer of substrate in structure begins at _____ ft; ends at _____ ft (measured from inlet)
- Substrate is continuous throughout structure

If present, substrate depth at inlet _____ ft; substrate depth at outlet _____ ft

SUBSTRATE PARTICLE SIZES number 1 up to 3 in order of sizes occupying most streambed area

	Bedrock	Boulders	Cobbles	Gravel	Sand	Silt/Clay	Organics	Aquatic macrophytes
Culvert								
Downstream near tailwater control								

BANKFULL channel widths---outside of culvert influence (ft): (1) _____ (2) _____
 (3) _____ (4) _____ (5) _____ **Average** _____

CALCULATIONS FROM SURVEY

Culvert slope: ____ % $\frac{\text{elev}(P_2 - P_4)}{\text{dist}(P_2 - P_4)} * 100$

Outlet drop (F): ____ (P₄ minus P₆)

Channel gradient: ____ % upst; ____ % downst

Inlet gradient: ____ % $\frac{\text{elev}(P_1 - P_2) \times (100)}{\text{dist}(P_1 - P_2)}$

Ratio of inlet width to channel width : ____

Residual inlet depth: ____ (P₆ - P₂)

Substrate ratio: ____ (depth of substrate/structure height)

Residual pool depth: ____ (P₆ - P₅)

FIELD PASSAGE EVALUATION (use if in different channel from structure 1)

__ **Resembles natural channel** __ **Passage adequate (species/lifestage)** _____
 __ **Passage indeterminate** __ **Passage inadequate (species/lifestage)** _____

Comments:

Crossing ID number _____ Structure ____ of ____

SITE SKETCH (Only use if this structure is at some distance from structure 1. All related structures should be on same sketch.)

Include:

North Arrow
Direction of stream flow
Inlet/channel alignment—include compass bearing for pool alignments
Lay of tape if needed
Photo point locations and numbers
Wingwalls and inlet / outlet aprons
Multiple structures
Baffle configurations
Weirs and other instream structures
Debris jams inside, upstream and downstream near site, depositional bars
Trash racks, screens, standpipes etc. that may affect passage
Damage to or obstacle inside structure
Location of Riprap for bank armoring or jump pool formation
Tailwater cross-section location